SERVICE MANUAL

Machine: U AC Power
Plus

Manual No: 005954

Edition 2010A

Hydraulic system

8.1 Introduction	8.3
8.1.1 Description	8.3
<hr/>	
8.2 Hydraulic system general regulations	8.5
8.2.1 Installation	8.5
8.2.2 Connections	8.5
8.2.3 Start up	8.6
8.2.4 Installation instruction for pipe couplings	8.6
<hr/>	
8.3 Hydraulic filter	8.10
8.3.1 Replace	8.10
<hr/>	
8.4 Pump motor	8.11
8.4.1 Dismantling	8.11
8.4.2 Replacing the motor bearings	8.12
8.4.3 Replacing the bearing housing	8.13
8.4.4 Assembly	8.13
<hr/>	
8.5 Suction hose	8.14
8.5.1 Replace	8.14
<hr/>	
8.6 Tank	8.16
8.6.1 Draining	8.16
<hr/>	
8.7 Cylinders	8.17
8.7.1 Dismantling the reach cylinder	8.17
8.7.2 Dismantling, assembling the reach cylinder	8.18
8.7.3 Bleeding the reach cylinder	8.19
8.7.4 Dismantling the tilt cylinder from the truck	8.20
8.7.5 Dismantling, assembling the tilt cylinder	8.20

8.8 Valves	8.21
8.8.1 Operation of control valve	8.21
8.8.2 Adjusting the working pressure	8.22
8.8.3 Emergency lowering valve	8.22
8.8.4 Troubleshooting control valve	8.23
8.8.5 Setting the hose rupture valve	8.24

8.9 Hydraulic control	8.25
8.9.1 Calibration	8.25

8.10 Hydraulic diagram	8.27
8.10.1 Revision list	8.27

8 Hydraulic system

8.1 Introduction

8.1.1 Description

The hydraulic system is pump speed controlled. The pump motor, pump, hydraulic oil tank and hydraulic oil filter are integrated in a module, which can be easily lifted out from the truck if necessary.

The hydraulic system consists of:

- an oil tank with integrated return oil filter (replaceable filter insert) and filter for air evacuation from the tank.
- a pump unit consisting of an electric motor and pump.
- an electrically operated valve assembly that consists of several different sections (number and design can vary due to different equipment).

An electrical signal is sent from the joystick to the ATCII when the hydraulic functions are manoeuvred. The ATCII then controls the hydraulic pump's speed and the electrically operated valves.

The hydraulic oil then goes from the valve assembly through the hydraulic pipes and hoses to the cylinders. Of these, only the lift cylinders are single acting, the others are all double acting. The lift cylinders are retracted by the weight of the fork carriage. In the double acting cylinders it is the oil pressure that retracts the piston rod.

A socket is located on the pressure pipe between the pump and the control valve for pressure measurement, see Figure 8.16.

Setting the lowering speed is done using an adjuster screw on the valve assembly, see section 8.8 Valves.

A hose rupture valve is located in the outlet of the lift cylinder which closes the oil flow if a hose ruptures and prevents the forks from falling down, see section 8.8.5 Setting the hose rupture valve for setting.

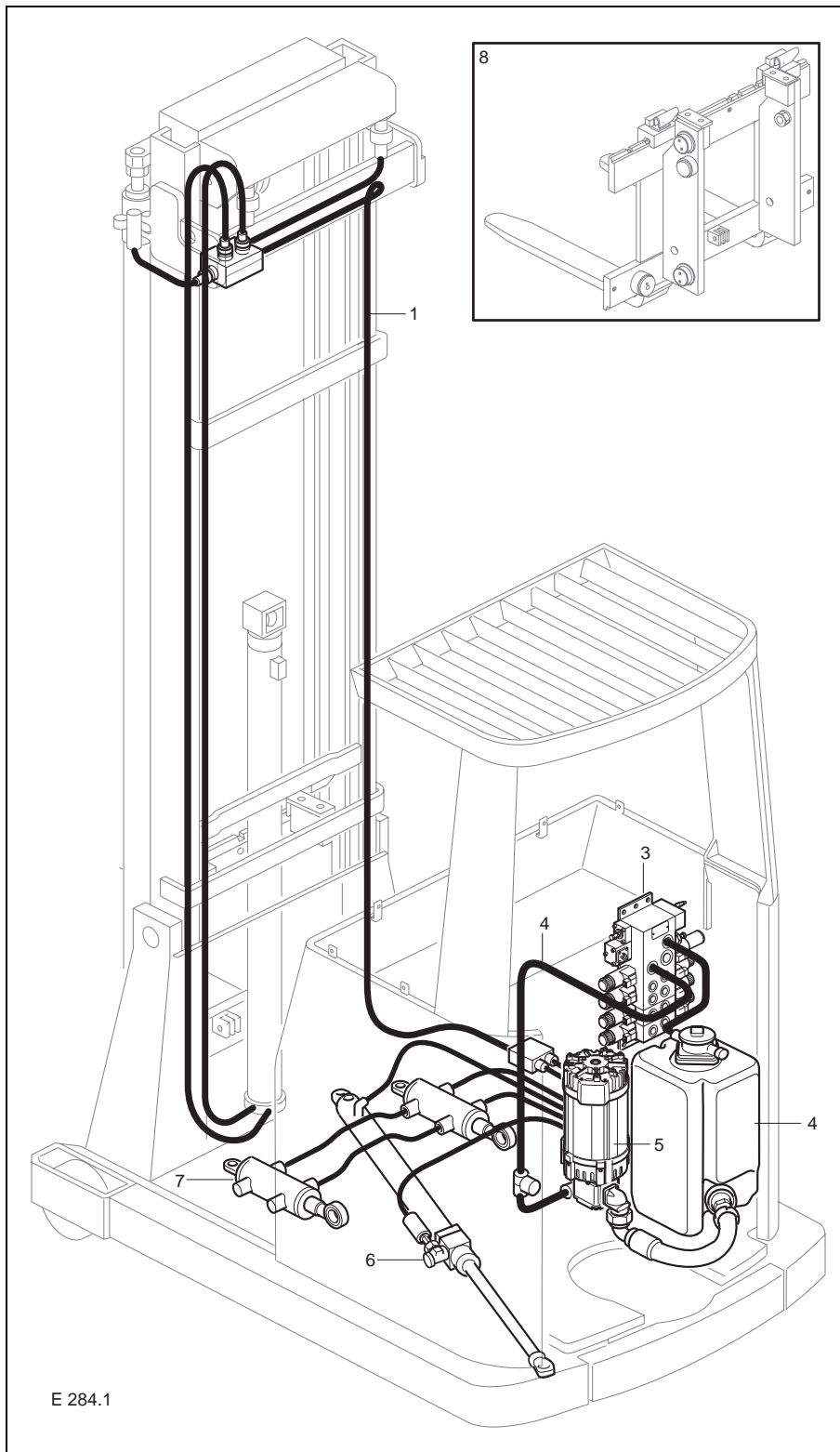

Figure 8.1

8.2 Hydraulic system general regulations



Important!

Cleanliness during all work with hydraulic components is of the greatest importance for the system's operating safety and service-life. The following should be taken into consideration:



Important!

Dirt particles must not get into components.

- Do not use cloths that release fibres or particles.
- Only use clean tools.
- Carefully clean tanks, pipes and hoses before installation.
- Welded or hot-bent pipes must be pickled (cleaning with acid bath) and washed before they are built in.
- The oil tank must be closed and provided with an efficient air filter to prevent dirt contaminating the hydraulic system.
- Sealing compounds such as flax, cement or thread tape are not permitted.
- Take into consideration the specified operating data.
- Do not exceed permitted pressures and volume flows.
- Do not exceed or go below the specified temperature range.
- Pay attention to specified electrical voltages and power consumption.

8.2.1 Installation

To prevent dirt and corrosion in the hydraulic system all hydraulic components should be provided with plastic plugs in the connections before they are delivered. Only remove these plugs just before the component is to be installed in the machine. Retaining screws and connections must correspond with those on the drawing. Retaining screws should not be tightened with a higher torque than that specified in the drawing. If such specifications are lacking the torque should not exceed the torque in the table in section 1.

8.2.2 Connections

Couplings should be fitted in accordance with the tightening torque in the table in section 1. We recommend couplings with elastic seals. Such couplings are necessary for proportional valves. Ring couplings do not seal at the low torque generally applicable for proportional valves.

Connect pipes and hoses in accordance with the hydraulic diagram. Pay attention to the connection designations. Do not use force; avoid building-in tensions in pipes, etc,

8.2.3 Start up

Check that everything is connected in accordance with the hydraulic diagram. Set the pressure limiting valves down to a very low pressure if they are not sealed. Start up with low pressure and volume flows.

Test the function and tightness of the system. Clean the system by allowing oil to pass over the filter a while, without loading the system (replace the filter insert at the recommended intervals). Check the oil level. Set the pressure and volume flows slowly to the values they should have. Check the connected measuring equipment regularly, where appropriate. Pay attention to the noise level; abnormal noise implies defects. Test during variable loads that components are correctly fitted, and that the system is tight.

In the event of returning equipment to the manufacturer, protect polished surfaces from damage and dirt by covering them with foil and protective paper. Fit plastic plugs in all connections. Send the complete components, not loose parts.

8.2.4 Installation instruction for pipe couplings

To achieve a safe and tight connection when installing pipe couplings in the hydraulic system, the following points should be taken into consideration:

1. The pipe should be cut at right angles by means of a pipe cutter, after which it is deburred internally and externally, and carefully cleaned.



Important!

When using a pipe cutter the end of the pipe becomes skew, with the formation of substantial burrs internally and externally. It is therefore important to straighten the end of the pipe and remove the burrs, both internally and externally.

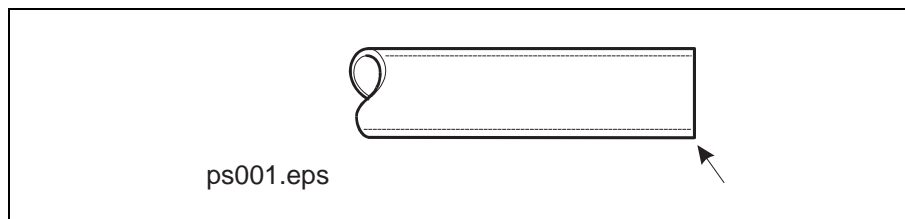

Figure 8.2 Cut the pipe at right angles and deburr lightly

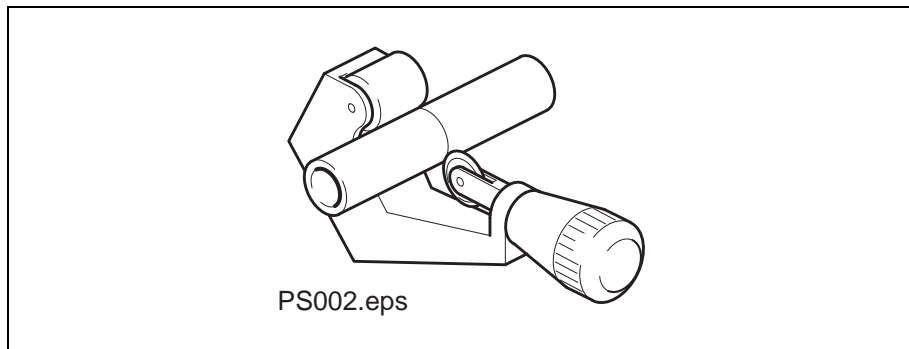

Figure 8.3 Pipe cutter

2. Oil in the thread and ring (not grease). Put the nut and ring over the pipe end as shown in the figure. If the ring cannot be worked over the pipe end it must absolutely not be enlarged. File down the pipe end instead.
3. Small pipe dimensions can be fitted directly in the coupling connected to the machine part. Screw the nut by hand until it lies flush with ring, press the pipe towards the shoulder in the coupling's cone, and tighten the nut a $\frac{3}{4}$ turn.



Important!

The pipe must not follow round.

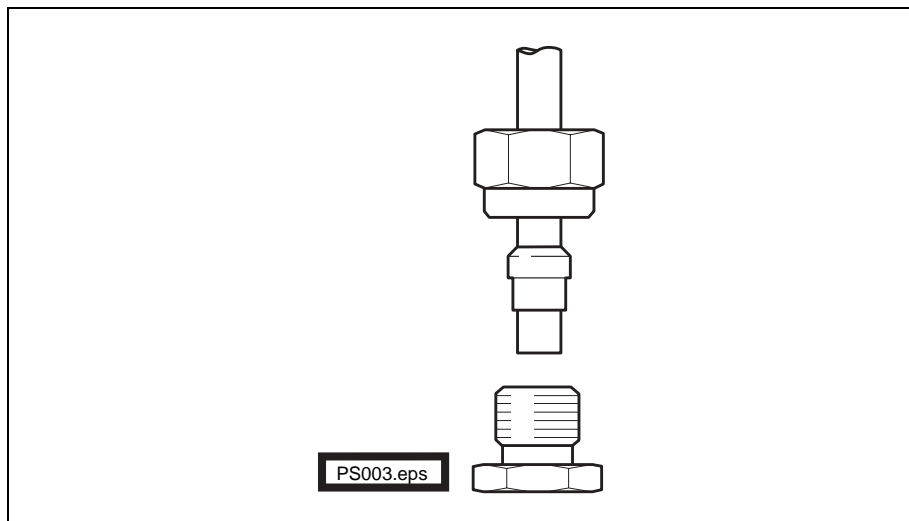

Figure 8.4

The ring will now have gripped the pipe, and no longer needs to be pressed against the shoulder. Complete the fitting with an additional $\frac{3}{4}$ turn of the nut. The ring has now cut into the pipe and in front of the ring there is a visible swelling of the pipe material.

4. Larger pipe dimensions and couplings in free pipes are preferably fitted by placing the coupling body in a vice. The U-ring spanner should be 15 times the nut width (can be extended with a piece of pipe). Otherwise fit according to point 3.



Important!

If several couplings of the same type are to be fitted, make sure that each pipe end goes in the same coupling cone it was previously fitted in.

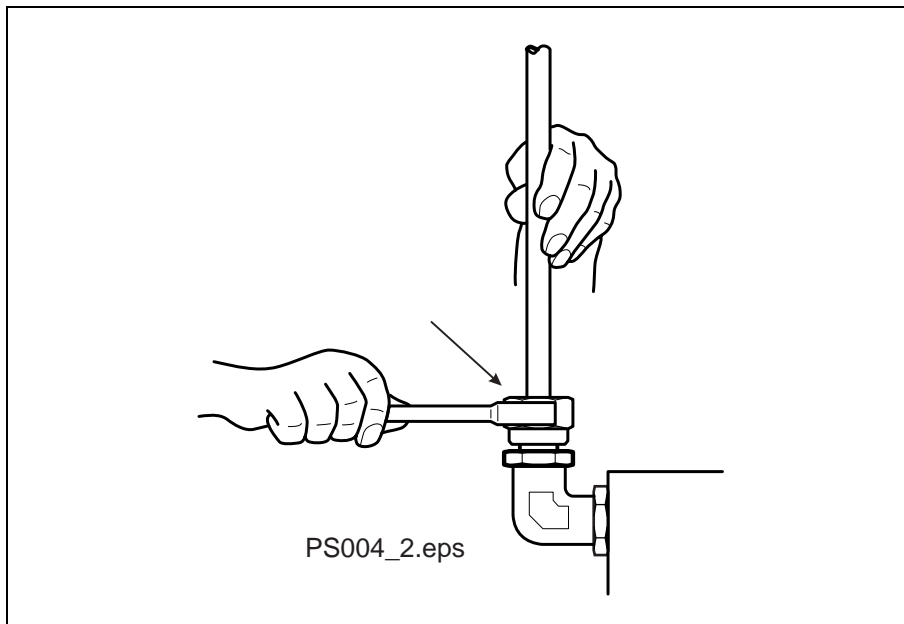

Figure 8.5 Marking the nut helps to follow the specified tightening.

Fitting is simplified if the nut is loosened and oil is applied between the friction surfaces.

5. After fitting, release the cap nut and check that the ring has pressed up a visible swelling in the area in front of it. If not, give it another short turn. It is of no importance whether the ring can be turned.



Important!

Repeated fitting: After each dismantling the nut should be fitted without extension of the U-ring spanner, and without excessive force.

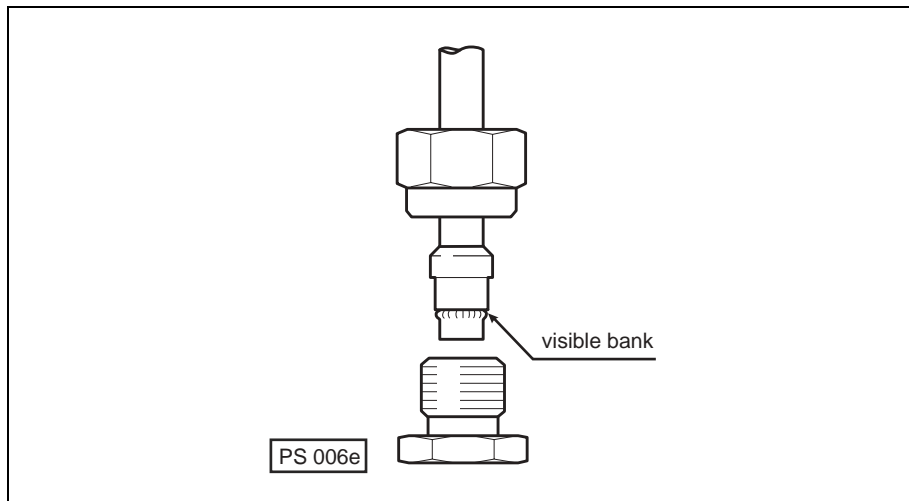
**Figure 8.6**

6. If the pipe is to be bent after a coupling, the straight pipe end should have a length of at least 2 nut heads, H . Long and heavily loaded pipes should be provided with pipe clips.

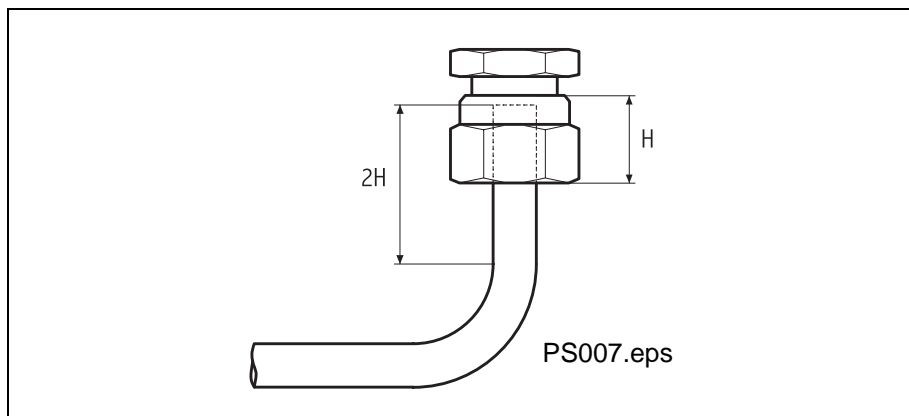
**Figure 8.7**

7. Final assembly should be done with at least 1 turn of the nut from the point where it cannot be turned by hand.

8.3 Hydraulic filter

8.3.1 Replace

1. Loosen the cover, pos 39.
2. Grip the filter insert, pos 38.
3. Lift out the insert. Hold, pos 37, in case it binds.
4. Fit the new insert. Press.
5. Assemble the cover, pos 39 (Do not tighten too hard).
6. Replace the air filter pos 46.



Important!

Work on the hydraulic components may only be done in a clean environment.
The system must be depressurised.

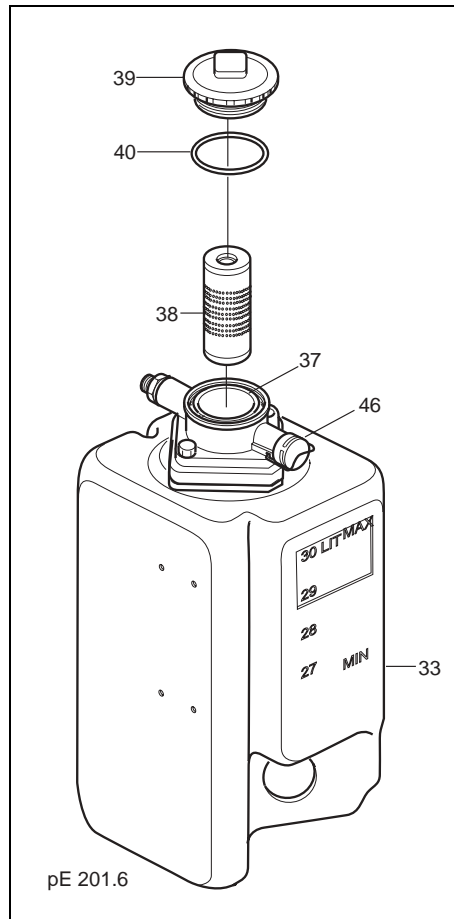

Figure 8.8

8.4 Pump motor

8.4.1 Dismantling

1. Drain the oil from the tank, see “Tank” on page 16.
2. Loosen the cable connections and check the coding.
3. Fit the lifting eyes in the pump motor.
4. Fit the lifting device in the lifting eyes.
5. Dismantle the suction hose (30) and hydraulic pipe (3).
6. Loosen the screws (24). Lift out the pump motor (21).

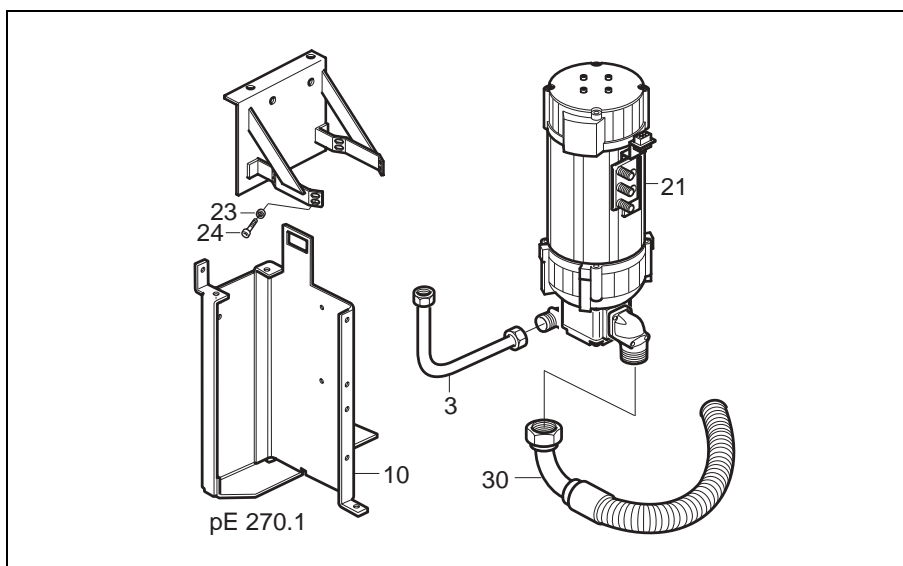

Figure 8.9 Dismantling the pump motor

8.4.2 Replacing the motor bearings

The motor bearings should always be replaced with reconditioning the motor to ensure continued reliable operations. The description below applies to motors from Sauer-Danfoss (2006w07-).

Dismantling

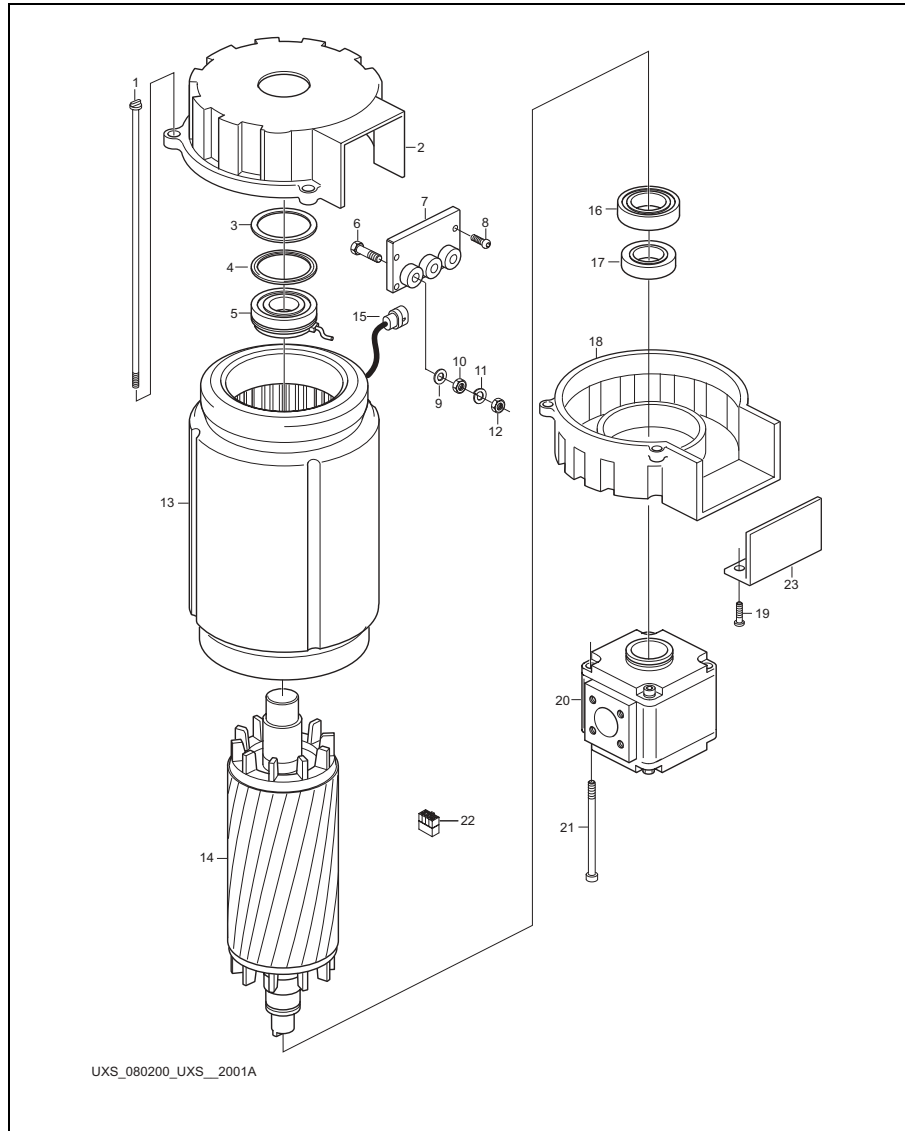

Figure 8.10 Pump motor

1. Dismantle the electrical connections to the motor.
2. Mark the position of the stator (13) in relation to the end-plate (2).
3. Dismantle the screws (1).
4. Remove the end-plate (2) and dismantle the rotor (14).
5. Push out the motor bearing (5) by hand
6. Remove the O-ring (4) and washer (3).

Assembly

Assemble in the reverse order.



Note!

Pay particular attention that the groove on the bearing is positioned correctly in the end-plate.

8.4.3 Replacing the bearing housing

The description below applies to motors from Sauer-Danfoss (2006w07-).

Dismantling

1. Dismantle the electrical connections to the motor.
2. Dismantle the pump (20).
3. Mark the position of the stator (13) in relation to the end-plate (2).
4. Dismantle the screws (1).
5. Remove the end-plates (18) and (2).
6. Dismantle the rotor (14).
7. Remove the ball bearing (16) and sealing ring (17).

Assembly



Note!

When the bearing housing has been removed a new ball bearing and a new sealing ring must be fitted.

1. Fit the ball bearing (16) and apply grease **FAG Arcanol TEMP90** or the like. Now fit the sealing ring (17).
2. Fit the remaining parts in the reverse order.

8.4.4 Assembly

Assemble in the reverse order.

8.5 Suction hose

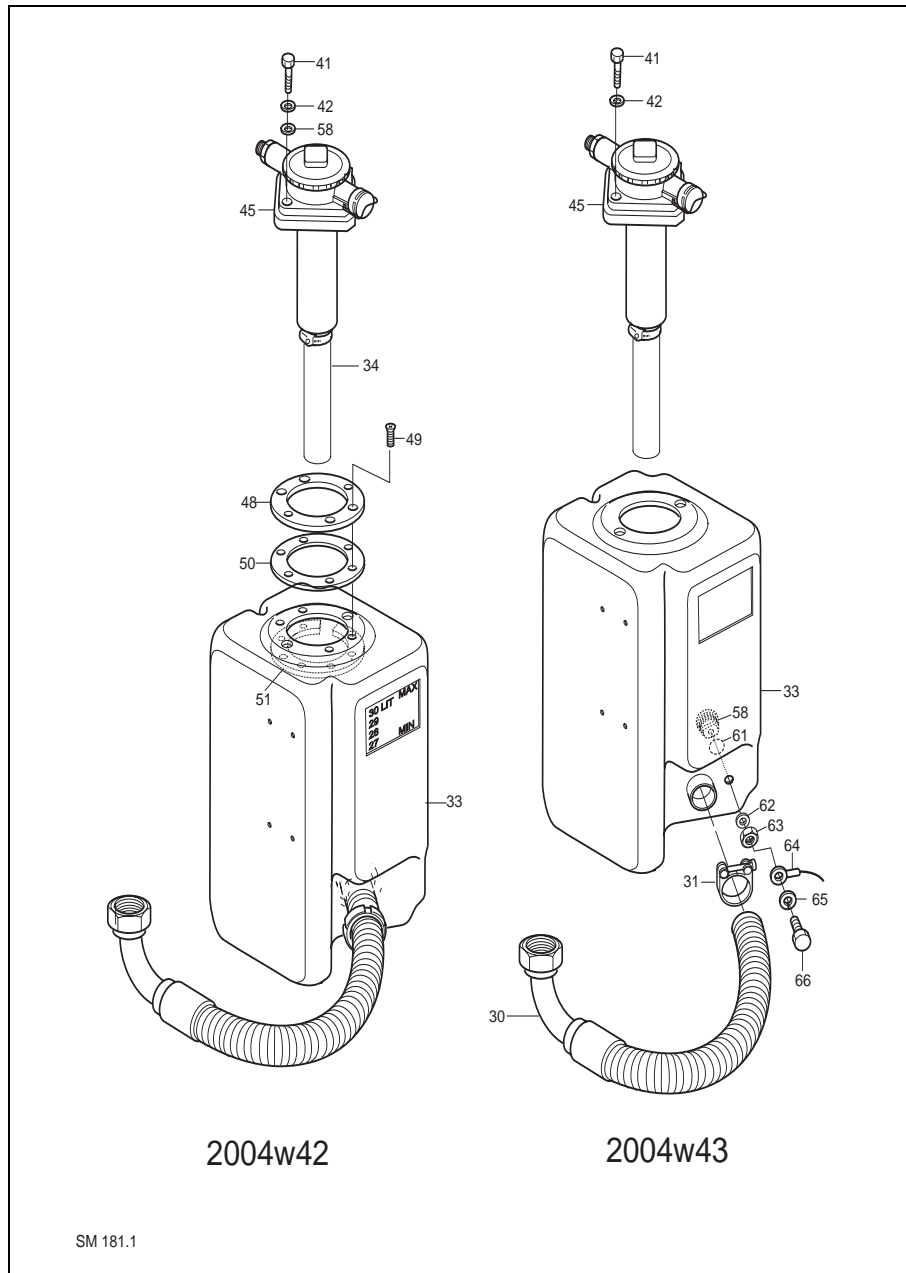

Figure 8.11

8.5.1 Replace

1. Empty the oil from the tank. see “Suction hose” on page 14.
2. Dismantle the hydraulic filter complete.
3. Loosen the suction hose from the pump.
4. Loosen the suction hose from the tank using an open-ended spanner and a hook spanner.
5. Lift out the suction hose through the hole for the filter.

6. Assemble in the reverse order. (Always fit new O-rings and connect the hose to the pump before tightening the tank connection, so that the hose routing will be correct.)
7. Fill with hydraulic oil through the filter.



Important!

Do not forget the earth connection between the suction line and the chassis.



Note!

The screws for the filter should be fitted with care to avoid damaging the threads in the tank.

8.6 Tank

8.6.1 Draining

1. Lower the forks to their lowest position and depressurise the system.
2. Loosen the rubber clamp holding the pressure hose on the battery wall.
3. Loosen the pressure hose from the valve.
4. Fold out the hose and place in a container..
5. Start the pump motor and carefully pump out the oil in a container. (Carry out slowly to prevent cavitation in the pump when the tank is empty.)



Warning!

Exercise care when loosening the hose and pump out the oil as this is under great pressure and can cause serious damage/injury.



Note!

Always use new oil when refilling.

8.7 Cylinders

Reach cylinders and tilt cylinders are double acting.

8.7.1 Dismantling the reach cylinder

1. Reach out the mast to its outermost position and lower the forks to their lowest position.
2. Loosen the nut, pos 12, in the rear mounting. The axle, pos 15, can be held using an Allen key from below.
3. Remove the axle, pos 15.
4. Retract the cylinder with the lever for the reach function by moving it backwards.
5. Pull out the battery plug.
6. Loosen and plug the pressure hose to the reach cylinder.
7. Remove the axle in the cylinder's front mounting.
8. Lift out the cylinder.

Assemble the cylinder in the reverse order.

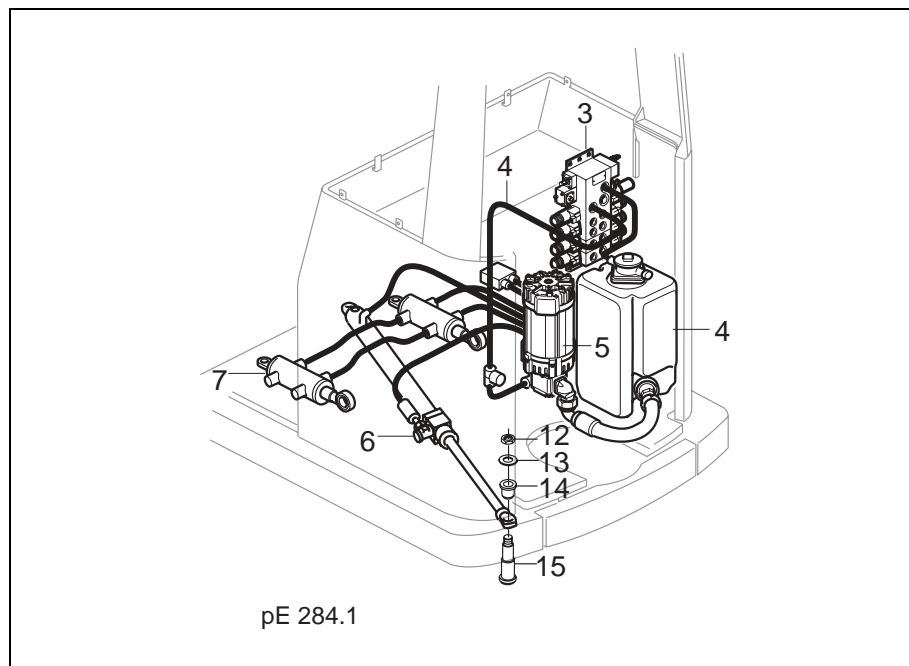

Figure 8.12

8.7.2 Dismantling, assembling the reach cylinder

1. Dismantle the link bearing, pos 11.
2. Dismantle the four bolts, pos 1.
3. Pull apart the cylinder.
4. Before assembling, change the seals and lubricate them with hydraulic oil.

Assemble in the reverse order.

Lifting out the reach cylinder:

Before the link bearing is mounted, operate the cylinder a number of times between its outer positions.

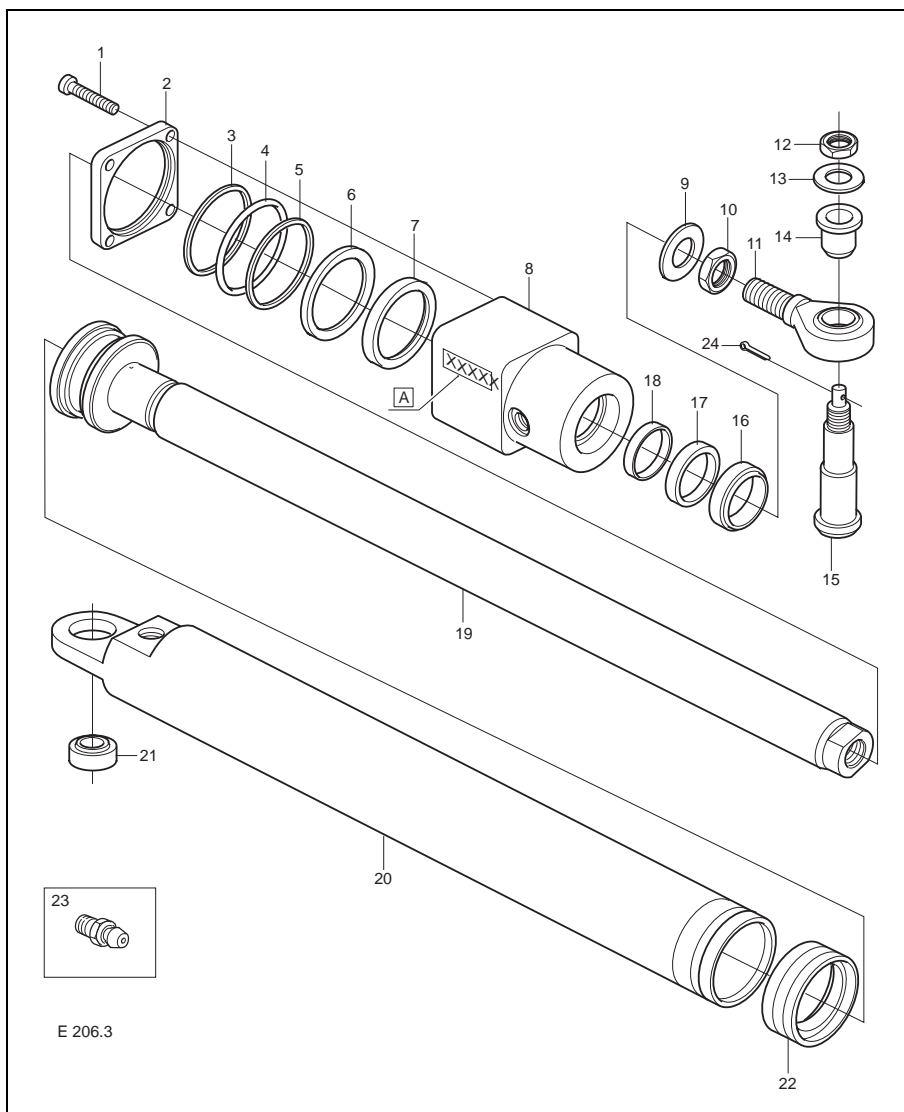

Figure 8.13

8.7.3 Bleeding the reach cylinder

If you suspect air to be in the cylinder (reach movement is jerky), the following operations can be done:

1. Move out the reach carriage.
2. Dismantle the axle, pos 15.
3. Run out the piston a little.



Important!

Check that the piston rod is not damaged.

4. Dismantle the link bearing, pos 11 from the piston rod. Dismantle the hexagonal nut and the tab washer, pos 9 and 10.
5. Run the cylinder slowly in and out, to its innermost and outermost positions, several times so that any air is pressed out.
6. Assemble the cylinder and make an operations test.

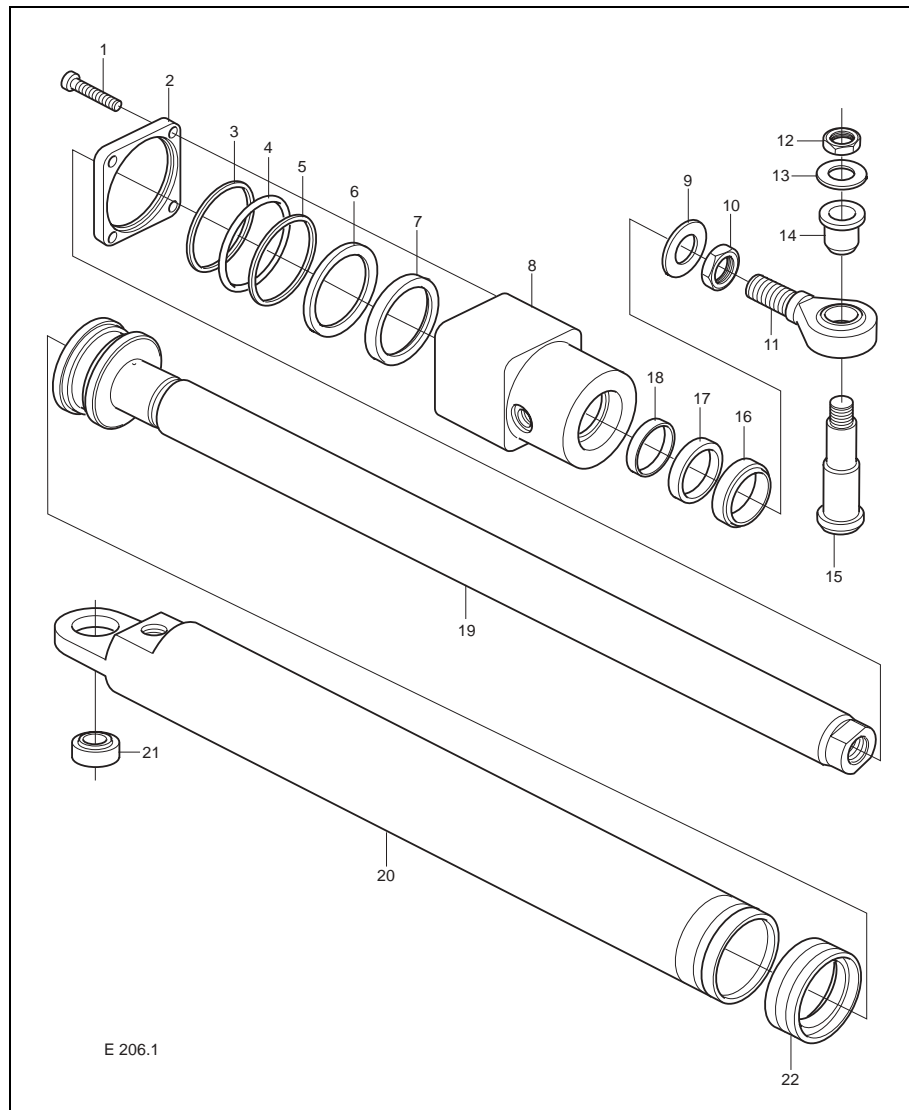

Figure 8.14

8.7.4 Dismantling the tilt cylinder from the truck



Warning!

When dismantling the tilt cylinders, one or both, the mast must be secured so that it does not tip backwards. Remember that a tilt cylinder can be faulty, which can cause an accident.

1. Tilt the mast to its foremost post and lower the forks to their lowest position.
2. Remove the pressure hoses to the cylinder.
3. Dismantle the axles on the front and rear mountings.
4. Lift out the cylinder.

8.7.5 Dismantling, assembling the tilt cylinder

1. Dismantle the link bearing, pos 4. Dismantle the four bolts.
2. Pull apart the cylinder.
3. Before assembling, change the seals and lubricate them with hydraulic oil.

Assemble in the reverse order.

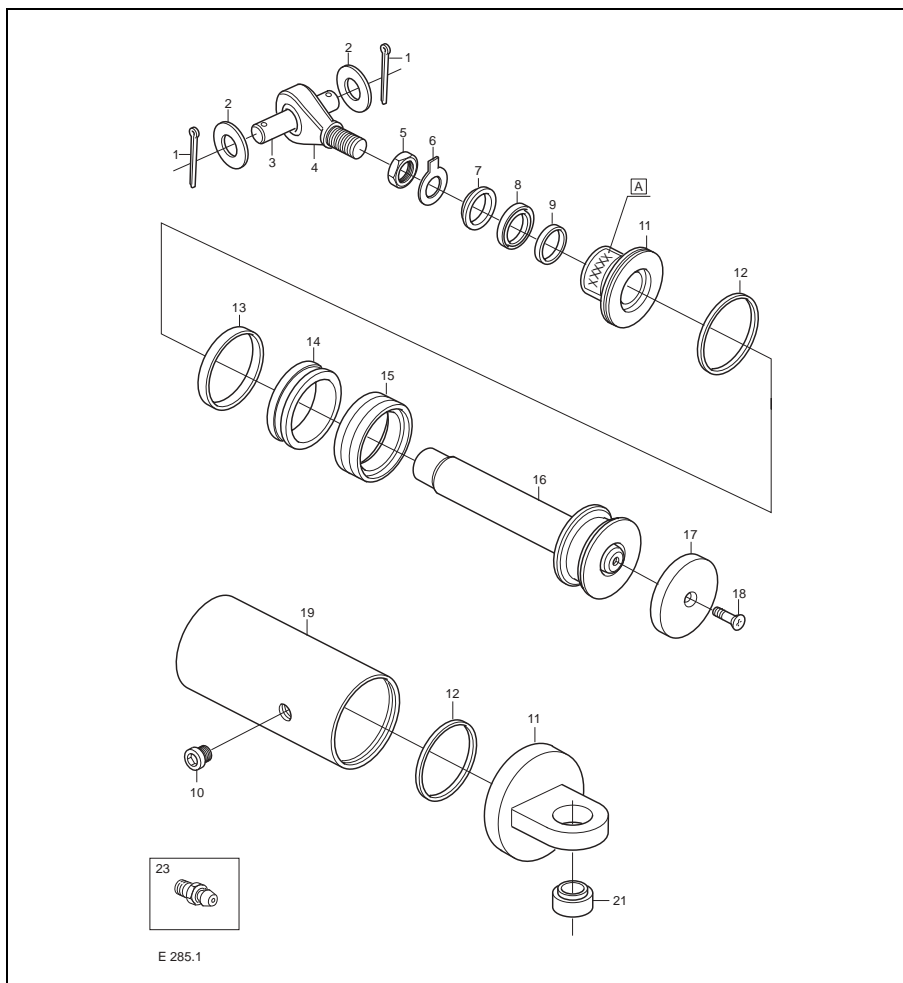

Figure 8.15

8.8 Valves

8.8.1 Operation of control valve

The control valve is an electrically controlled valve. The design of the valve puts high demands on careful handling and cleanliness. The contact's surfaces between the sections should be protected so that impact marks and scratches do not occur. This also applies to the connection ports. All components shall be cleaned, especially the valve housing, which should be inspected so that it is free of dirt before assembly.

Before you start work you should:

- Make sure the workplace is clean.
- Make sure tools and parts are clean.
- Make sure you have the right tools.

Make sure you have a spare parts list available, to check parts.

1. Emergency lowering control
2. Lowering speed adjustment
3. Pressure limit valve
4. Proportional valve for the lowering function
5. Inlet screen
6. Solenoid valve

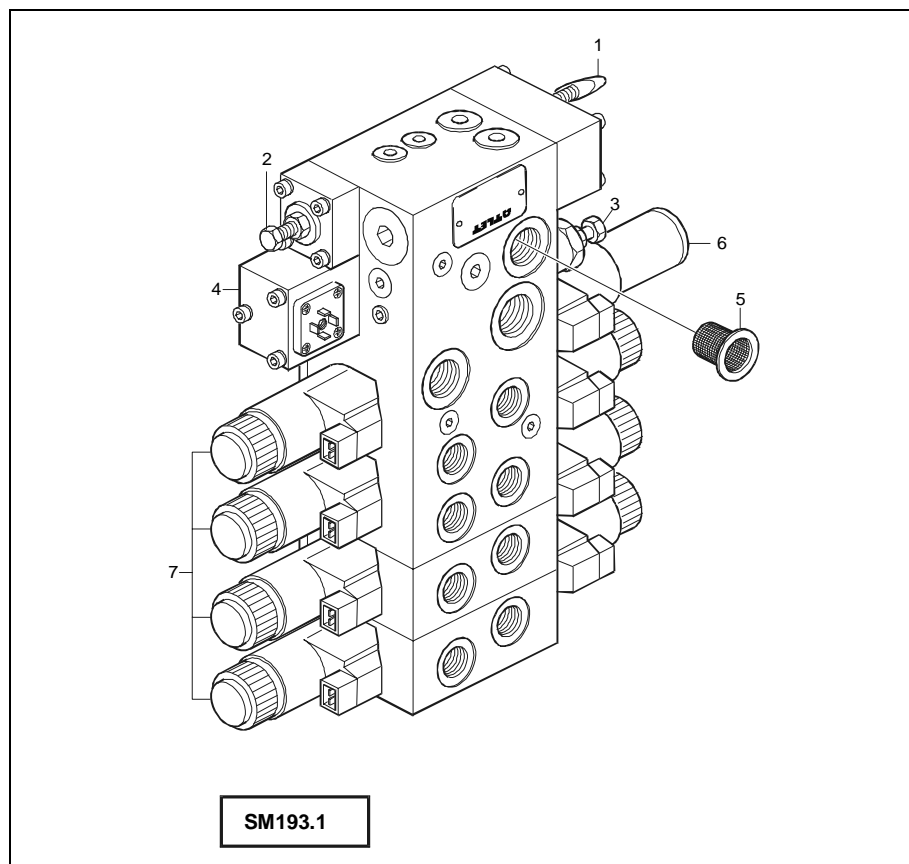

Figure 8.16