

4. BLADE CONTROL (Blade RAISE)

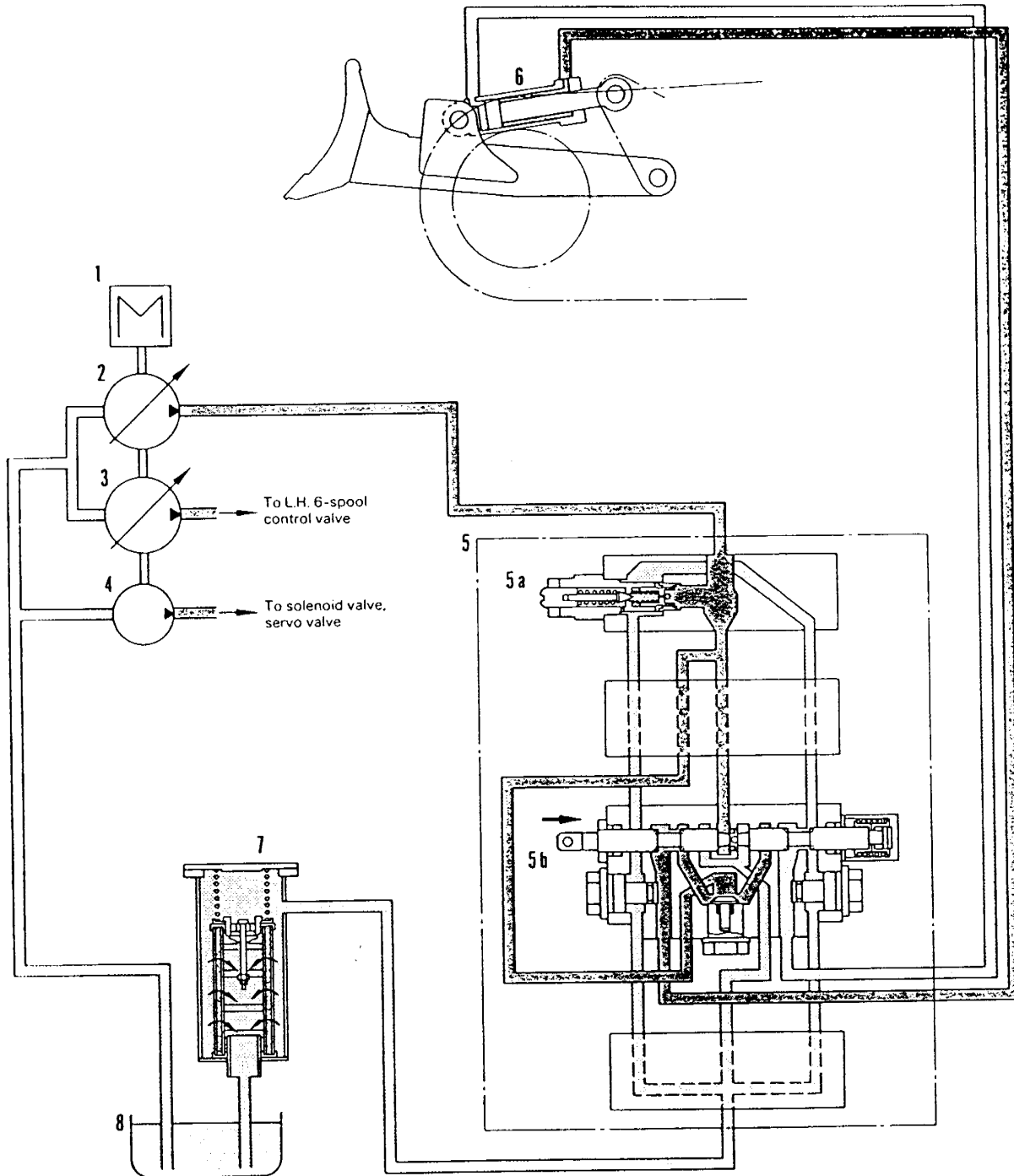

F201M5105

WORK EQUIPMENT

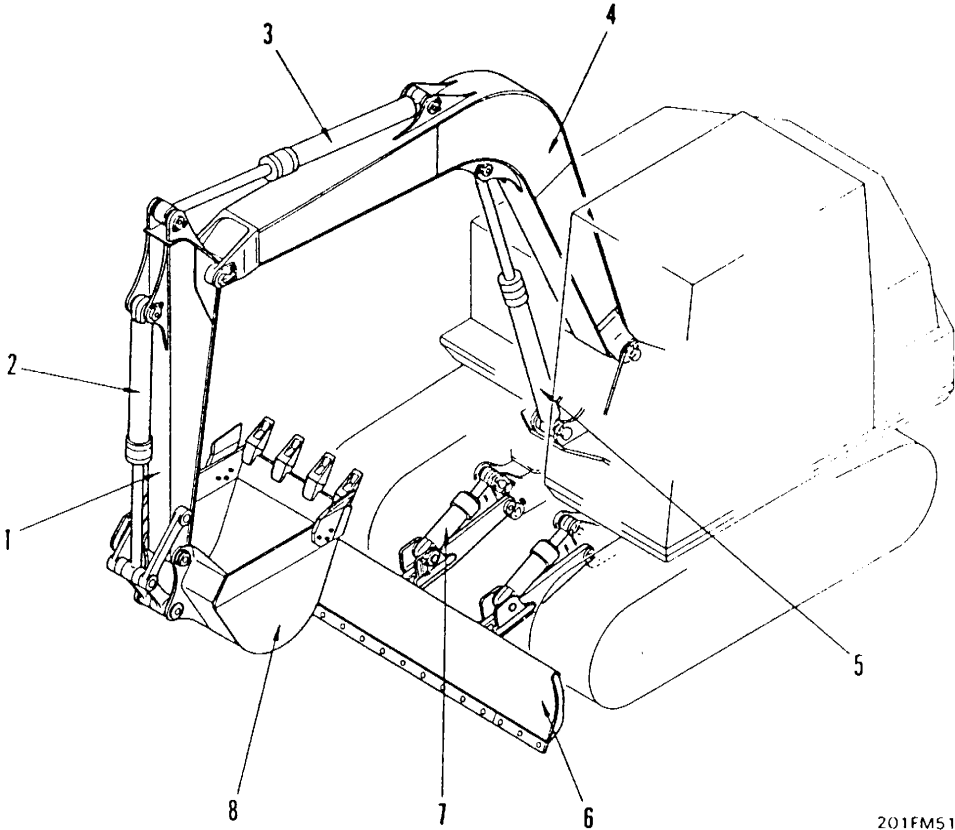

- 1. Arm
- 2. Bucket cylinder
- 3. Arm cylinder
- 4. Boom
- 5. Boom cylinder
- 6. Blade
- 7. Blade cylinder
- 8. Bucket

201FM5112

HYDRAULIC SYSTEM

62 TESTING AND ADJUSTING

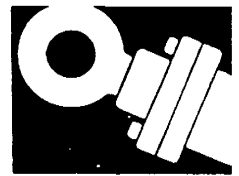
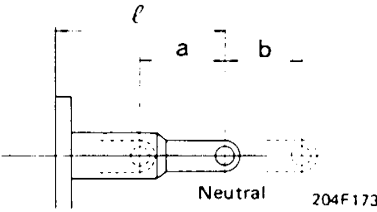
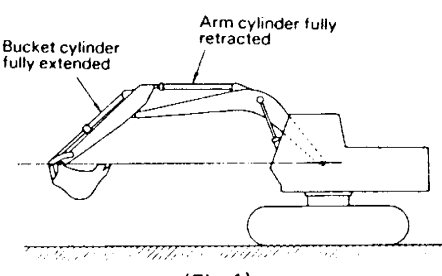
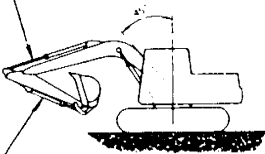

Table of judgement standard value	62- 2
Measuring hydraulic oil temperature	62- 9
Testing operating force of control levers	62-10
Testing travel of control levers	62-11
Testing travel of control valve spools	62-12
Testing and adjusting main relief valve	62-13
Testing and adjusting charging pump relief valve	62-14
Measuring delivery of piston pump	62-15
Checking performance of work equipment	62-16
Air bleeding	62-20
Checking travel motor performance	62-21
Checking performance of swing motors	62-23
Measuring oil leakage from swing and travel motors	62-24
Measuring oil leakage from center swivel joint	62-25
Checking visually or by "feel"	62-27
Troubleshooting	62-31

TABLE OF STANDARD VALUES

Item		Condition	Standard value (New machine)			Permissible value		
Engine	Engine low idling speed	<ul style="list-style-type: none"> Engine oil pressure: Inside operating range Engine coolant temperature: Inside operating range 	850 – 900 rpm					
	Engine high idling speed		2250 – 2350 rpm					
	Engine speed when one main pump circuit oil is relieved.	<ul style="list-style-type: none"> Hydraulic oil temperature: 45 – 55°C Engine oil pressure: Inside operating range Engine coolant temperature: Inside operating range At one pump relief: Bucket circuit relief At two pump relief: Bucket and arm circuits relief 	2100 rpm			2100 rpm		
	Engine speed when two main pump circuit oil is relieved.		2100 rpm			2100 rpm		
	Engine speed when auto-deceleration acts.	<ul style="list-style-type: none"> Fuel control lever at "High idling" Work equipment control lever at "Hold" 	1500 – 1700 rpm			1500 – 1700 rpm		
Spool travel	Boom Lo control valve		ℓ	a	b	ℓ	a	b
	Boom Hi control valve							
	Arm Lo control valve							
	Arm Hi control valve							
	Bucket control valve							
	Boom swing control valve							
	Swing control valve							
	L.H. travel control valve							
	R.H. travel control valve							
	Service valve							
					33 mm	6.5 ± 0.5 mm	6.5 ± 0.5 mm	33 mm
Control lever and pedal travel (mm)	Boom control lever	<ul style="list-style-type: none"> At center of lever knob 	Neu- tral →	Raise or Lower	160 ± 40	160 ± 40		
	Arm control lever	<ul style="list-style-type: none"> Measure maximum valve in traveling 	Neu- tral →	Arm in or out	130 ± 30	130 ± 30		
	Bucket control lever	<ul style="list-style-type: none"> Engine stopped 	Neu- tral →	Curl or Dump	110 ± 27	110 ± 27		
	Swing control lever		Neu- tral →	Swing right or swing left	120 ± 30	120 ± 30		
	Boom swing control lever		Neu- tral →	Swing right or swing left				
	Travel control lever		N →	Forward or Reverse (L.H., R.H.)	100 ± 25	100 ± 25		
	Fuel control lever		Stop ↔	Low idling	41 ± 12	41 ± 12		
			Low idling ↔ High idling	138 ± 20	138 ± 20			

Item	Condition	Standard value (New machine)	Permissible value		
0 1 2 3 4 5 6 7 8 9 10 11 12 13 14 15 16 17 18 19 20 21 22 23 24 25 26 27 28 29 30 31 32 33 34 35 36 37 38 39 40 41 42 43 44 45 46 47 48 49 50 51 52 53 54 55 56 57 58 59 60 61 62 63 64 65 66 67 68 69 70 71 72 73 74 75 76 77 78 79 80 81 82 83 84 85 86 87 88 89 90 91 92 93 94 95 96 97 98 99 100 101 102 103 104 105 106 107 108 109 110 111 112 113 114 115 116 117 118 119 120 121 122 123 124 125 126 127 128 129 130 131 132 133 134 135 136 137 138 139 140 141 142 143 144 145 146 147 148 149 150 151 152 153 154 155 156 157 158 159 160 161 162 163 164 165 166 167 168 169 170 171 172 173 174 175 176 177 178 179 180 181 182 183 184 185 186 187 188 189 190 191 192 193 194 195 196 197 198 199 200 201 202 203 204 205 206 207 208 209 210 211 212 213 214 215 216 217 218 219 220 221 222 223 224 225 226 227 228 229 230 231 232 233 234 235 236 237 238 239 240 241 242 243 244 245 246 247 248 249 250 251 252 253 254 255 256 257 258 259 260 261 262 263 264 265 266 267 268 269 270 271 272 273 274 275 276 277 278 279 280 281 282 283 284 285 286 287 288 289 290 291 292 293 294 295 296 297 298 299 300 301 302 303 304 305 306 307 308 309 310 311 312 313 314 315 316 317 318 319 320 321 322 323 324 325 326 327 328 329 330 331 332 333 334 335 336 337 338 339 340 341 342 343 344 345 346 347 348 349 350 351 352 353 354 355 356 357 358 359 360 361 362 363 364 365 366 367 368 369 370 371 372 373 374 375 376 377 378 379 380 381 382 383 384 385 386 387 388 389 390 391 392 393 394 395 396 397 398 399 400 401 402 403 404 405 406 407 408 409 410 411 412 413 414 415 416 417 418 419 420 421 422 423 424 425 426 427 428 429 430 431 432 433 434 435 436 437 438 439 440 441 442 443 444 445 446 447 448 449 450 451 452 453 454 455 456 457 458 459 460 461 462 463 464 465 466 467 468 469 470 471 472 473 474 475 476 477 478 479 480 481 482 483 484 485 486 487 488 489 490 491 492 493 494 495 496 497 498 499 500 501 502 503 504 505 506 507 508 509 510 511 512 513 514 515 516 517 518 519 520 521 522 523 524 525 526 527 528 529 530 531 532 533 534 535 536 537 538 539 540 541 542 543 544 545 546 547 548 549 550 551 552 553 554 555 556 557 558 559 560 561 562 563 564 565 566 567 568 569 570 571 572 573 574 575 576 577 578 579 580 581 582 583 584 585 586 587 588 589 590 591 592 593 594 595 596 597 598 599 600 601 602 603 604 605 606 607 608 609 610 611 612 613 614 615 616 617 618 619 620 621 622 623 624 625 626 627 628 629 630 631 632 633 634 635 636 637 638 639 640 641 642 643 644 645 646 647 648 649 650 651 652 653 654 655 656 657 658 659 660 661 662 663 664 665 666 667 668 669 670 671 672 673 674 675 676 677 678 679 680 681 682 683 684 685 686 687 688 689 690 691 692 693 694 695 696 697 698 699 700 701 702 703 704 705 706 707 708 709 710 711 712 713 714 715 716 717 718 719 720 721 722 723 724 725 726 727 728 729 730 731 732 733 734 735 736 737 738 739 740 741 742 743 744 745 746 747 748 749 750 751 752 753 754 755 756 757 758 759 760 761 762 763 764 765 766 767 768 769 770 771 772 773 774 775 776 777 778 779 780 781 782 783 784 785 786 787 788 789 790 791 792 793 794 795 796 797 798 799 800 801 802 803 804 805 806 807 808 809 810 811 812 813 814 815 816 817 818 819 820 821 822 823 824 825 826 827 828 829 830 831 832 833 834 835 836 837 838 839 840 841 842 843 844 845 846 847 848 849 850 851 852 853 854 855 856 857 858 859 860 861 862 863 864 865 866 867 868 869 870 871 872 873 874 875 876 877 878 879 880 881 882 883 884 885 886 887 888 889 890 891 892 893 894 895 896 897 898 899 900 901 902 903 904 905 906 907 908 909 910 911 912 913 914 915 916 917 918 919 920 921 922 923 924 925 926 927 928 929 930 931 932 933 934 935 936 937 938 939 940 941 942 943 944 945 946 947 948 949 950 951 952 953 954 955 956 957 958 959 960 961 962 963 964 965 966 967 968 969 970 971 972 973 974 975 976 977 978 979 980 981 982 983 984 985 986 987 988 989 990 991 992 993 994 995 996 997 998 999 1000	<ul style="list-style-type: none"> Engine speed: High idling Hydraulic oil temperature: 45 – 55°C Hook push-pull scale on center of control lever knob to measure Measure maximum value in traveling 	Neutral → Raise Neutral → Lower Neutral → Curl or dump Neutral → Swing right or swing left Neutral → Swing right or swing left Lever Forward Reverse Pedal Forward Reverse	1.8 – 2.2 1.3 – 1.7 1.8 – 2.2 1.4 – 1.8 1.7 – 2.1 1.9 – 2.3 1.4 – 1.8 3.7 – 4.7 4.1 – 5.1	2.4 1.9 2.4 2.0 2.3 2.5 2.0 5.9 6.4	
	Boom Arm Travel Bucket Swing Charging pump	<ul style="list-style-type: none"> Engine speed: High idling Hydraulic oil temperature: 45 – 55°C 1 pump relieved, other pump no load 		$300 \begin{smallmatrix} +10 \\ 0 \end{smallmatrix} \text{ kg/cm}^2$ $230 \begin{smallmatrix} +10 \\ 0 \end{smallmatrix} \text{ kg/cm}^2$ $230 \begin{smallmatrix} +20 \\ 0 \end{smallmatrix} \text{ kg/cm}^2$ $30 \begin{smallmatrix} +1 \\ 0 \end{smallmatrix} \text{ kg/cm}^2$	$320 \begin{smallmatrix} +20 \\ 30 \end{smallmatrix} \text{ kg/cm}^2$ $250 \begin{smallmatrix} +20 \\ 0 \end{smallmatrix} \text{ kg/cm}^2$ $260 \begin{smallmatrix} +20 \\ 0 \end{smallmatrix} \text{ kg/cm}^2$ $30 \pm 3 \text{ kg/cm}^2$
	Lowered hydraulic pressure	<ul style="list-style-type: none"> Hydraulic oil temperature: 45 – 55°C Difference oil relief pressure between at engine full speed and at engine a half speed. (Measure pressure when one pump circuit oil is relieved.) 		Max. 30 kg/cm ²	Max. 30 kg/cm ²
	Movement when stopping swing (Swing brake angle)	 <ul style="list-style-type: none"> Engine speed: High idling Hydraulic oil temperature: 45 – 55°C Bucket unloaded Write 2 match marks on outside of upper and lower swing circles Stop the normal swing at 2 match marks fitted Measure difference between 2 match marks (): Swing brake angle 		Max. 409 mm (Max. 55°)	Max. 483 mm (Max. 60°)

Item		Condition	Standard value (New machine)		Permissible value
Swing	Time taken to start swing	<ul style="list-style-type: none"> Engine speed: High idling Hydraulic oil temperature: 45 – 55°C Bucket unloaded Measure time taken for 90° – 180° swing from starting point with work equipment in posture in Fig. 1 	90°	1.9 ± 0.3 sec.	Max. 2.5 sec.
			180°	2.9 ± 0.3 sec.	Max. 3.5 sec.
	Time taken to swing	<ul style="list-style-type: none"> Engine speed: High idling Hydraulic oil temperature: 45 – 55°C Bucket unloaded Work equipment in posture in Fig. 1 Measure time taken to swing for 5 turns, after swinging one turn as an approach swing 		21.4 ± 1.1 sec.	Max. 25 sec.
	Hydraulic drift of swing	<ul style="list-style-type: none"> Engine speed: Stopped Hydraulic oil temperature: 45 – 55°C Work equipment in posture in Fig. 1 Bucket unloaded Swing lock switch is in ON. (With swing lock brake system) Stop the machine on 15° slope and set boom at 90° angle across the slope Measure distance moved by outside of swing circle in 5 min. 		0 mm	0 mm
Leakage from swing motor	<ul style="list-style-type: none"> Engine speed: High idling Hydraulic oil temperature: 45 – 55°C Relieve swing circuit Measure leakage from swing motor with measuring cylinder 		Max. 1.5 ℓ/min.	2.5 ℓ/min.	
Travel	Travel speed (1)	<ul style="list-style-type: none"> Engine speed: High idling Hydraulic oil temperature: 45 – 55°C Raise track on one side, then measure time taken to rotate for 5 turns after rotating one turn as an approach travel Repeat same way with track on other side 	130	26.9 ± 2 sec.	130 Max. 31 sec.
	Travel speed (2)	<ul style="list-style-type: none"> Engine speed: High idling Hydraulic oil temperature: 45 – 55°C Machine is on level ground Measure time taken to travel for 20 m after traveling 10 m as an approach travel Work equipment posture: <div style="text-align: center;">  <p>Arm cylinder fully extended</p> <p>202F2309</p> <p>Bucket cylinder fully extended</p> </div>		18.9 ± 0.9 sec.	18.9 ^{+2.9} _{-0.9} sec.

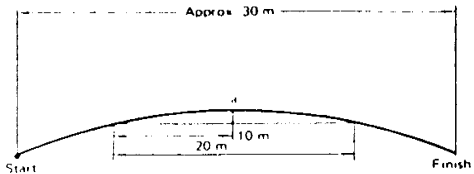
Item		Condition	Standard value (New machine)	Permissible value	
Travel	Travel deviation	 <ul style="list-style-type: none"> Engine speed: High idling Hydraulic oil temperature: 45 – 55°C Run the machine for about 30 m on firm and level ground. Lay out a 20 m string from a point 5 to 6 m from the start, and measure the deviation (a) of the machine at the midway point (10 m mark). 	Max. 200 mm	Max. 220 mm	
	Hydraulic drift of travel	<ul style="list-style-type: none"> Engine speed: Stopped Hydraulic oil temperature: 45 – 55°C Stop the machine on 12° slope with setting sprocket on uphill Measure distance moved by machine in 5 minutes. 	0 mm	0 mm	
	Leakage from travel motor	<ul style="list-style-type: none"> Engine speed: High idling Hydraulic oil pressure: 45 – 55°C Block track to relieve circuit Measure leakage from travel motor with measuring cylinder 	Max. 0.520 ℓ/min.	Max. 1 ℓ/min.	
Work equipment	Work equipment speed	Boom	<ul style="list-style-type: none"> Engine speed: High idling Hydraulic oil temperature: 45 – 55°C Bucket unloaded Arm and bucket cylinder fully retracted Measure time taken from bucket tooth touching the ground to boom cylinder fully extended (RAISE) Measure time taken from boom cylinder fully extended to bucket tooth touching the ground (LOWER) 	RAISE 2.5 ± 0.3 sec. LOWER 2.3 ± 0.2 sec.	Max. 3.1 sec. Max. 2.8 sec.
		Arm	<ul style="list-style-type: none"> Engine speed: High idling Hydraulic oil temperature: 45 – 55°C Bucket unloaded Top of boom is in horizontal, and bucket cylinder fully retracted Measure time taken from arm cylinder fully retracted position to cylinder fully extended position (IN) Measure time taken cylinder fully extended position to cylinder fully retracted position (OUT) 	IN 3.2 ± 0.3 sec. OUT 2.5 ± 0.3 sec.	Max. 3.9 sec. Max. 3.1 sec.
		Bucket	<ul style="list-style-type: none"> Engine speed: High idling Hydraulic oil temperature: 45 – 55°C Bucket unloaded Top of boom is in horizontal, and arm cylinder fully retracted Measure time taken from cylinder fully retracted position to cylinder fully extended position (CURL) Measure time taken from cylinder fully extended position to cylinder fully retracted position (DUMP) 	CURL 4.2 ± 0.4 sec. DUMP 2.8 ± 0.3 sec.	Max. 5.1 sec. Max. 3.4 sec.

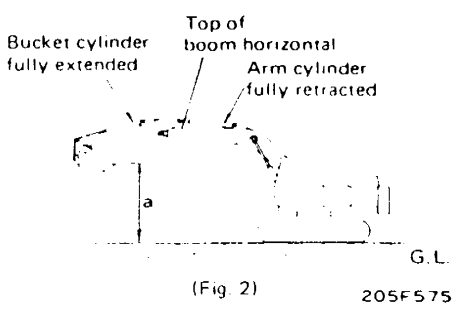
Item		Condition	Standard value (New machine)	Permissible value
Work equipment	Hydraulic drift	 <p>(Fig. 2) 205F575</p> <ul style="list-style-type: none"> · Engine speed: Stopped · Hydraulic oil temperature: 45 – 55°C · Bucket loaded · Work equipment in posture in Fig. 2 · Measure amount bucket tooth moved down (distance "a") in 15 min. · Measure immediately after setting 	Max. 550 mm	Max. 825 mm
		<ul style="list-style-type: none"> · Engine speed: Stopped · Hydraulic oil temperature: 45 – 55°C · Bucket rated loaded · Work equipment in posture in Fig. 2 · Measure amount boom cylinder retracted in 15 min. 	Max. 39 mm	Max. 59 mm
		<ul style="list-style-type: none"> · Engine speed: Stopped · Hydraulic oil temperature: 45 – 55°C · Bucket rated loaded · Work equipment in posture in Fig. 2 · Measure amount arm cylinder extended in 15 min. 	Max. 39 mm	Max. 59 mm
		<ul style="list-style-type: none"> · Engine speed: Stopped · Hydraulic oil temperature: 45 – 55°C · Bucket rated loaded · Work equipment in posture in Fig. 1 · Measure amount bucket cylinder retracted in 15 min. 	Max. 10 mm	Max. 15 mm
Internal leakage	Each cylinder	<ul style="list-style-type: none"> · Hydraulic oil temperature: 45 – 55°C · Operating pressure: $300 \begin{smallmatrix} +5 \\ 0 \end{smallmatrix} \text{ kg/cm}^2$ 	Max. 1.5 cc/min.	Max. 7.5 cc/min.
	Center swivel joint		Max. 10 cc/min.	Max. 50 cc/min.
	Work equipment swivel joint		Max. 10 cc/min.	Max. 50 cc/min.