

A402770

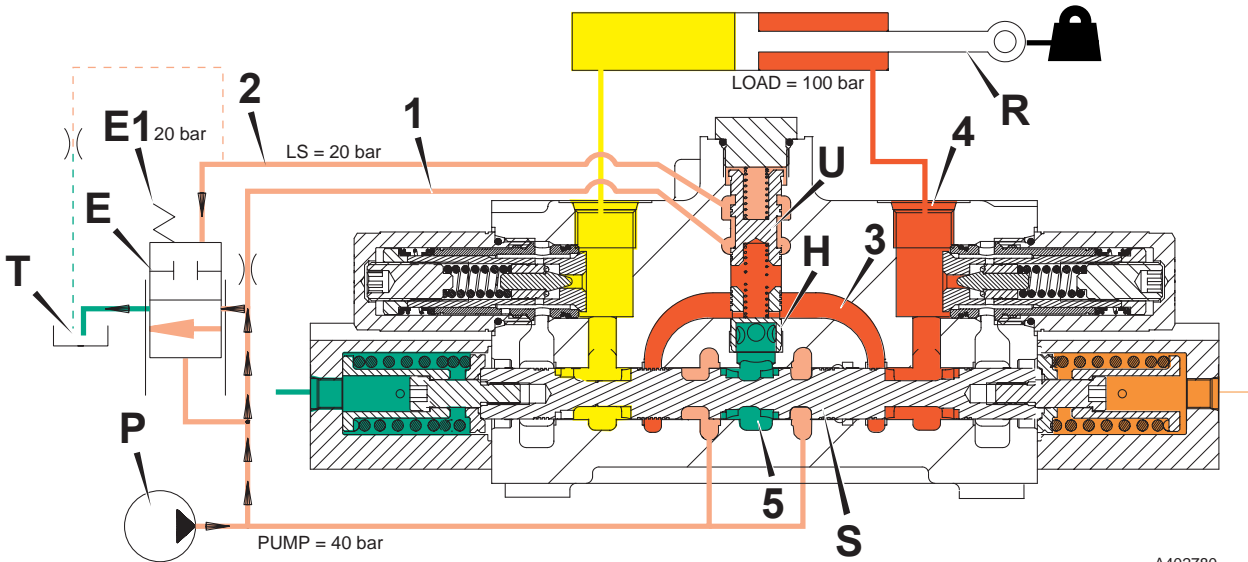

A402780

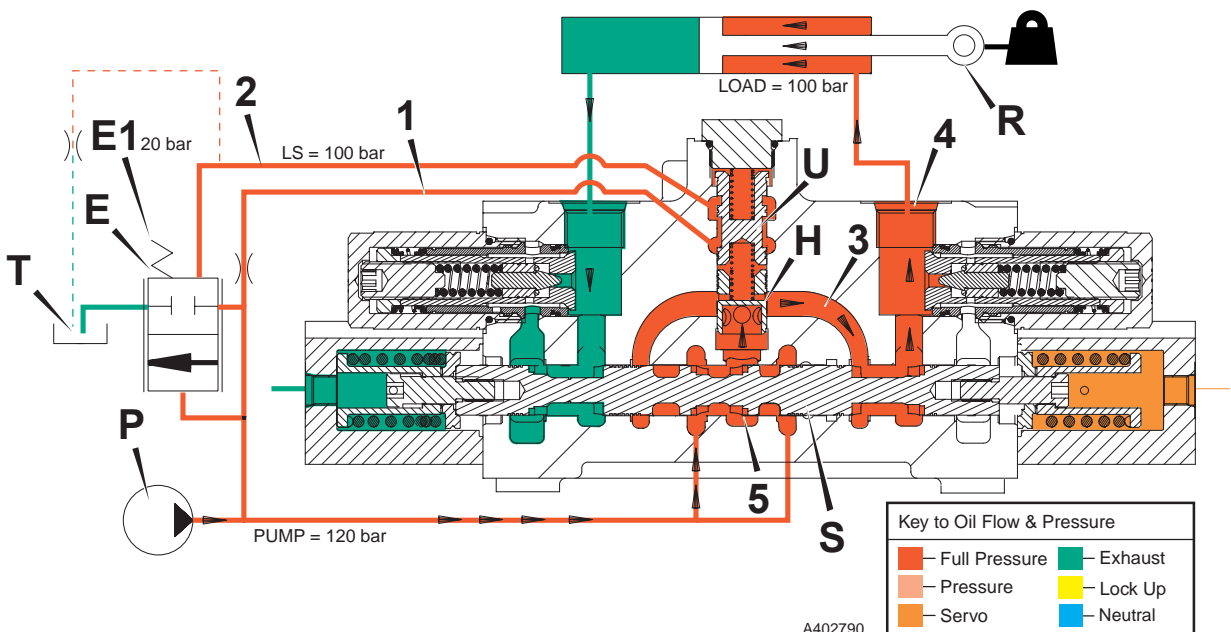

Key to Oil Flow & Pressure

Red	Full Pressure	Green	Exhaust
Light Red	Pressure	Yellow	Lock Up
Orange	Servo	Blue	Neutral

A402790

## Excavator Valve

### Precision Control (Servo) (continued)

\* (Machines up to serial no. 931159)

### Load Sense (Isolator Compensator) Valve Operation

#### No service is selected (all spools in neutral)

With the spools in the neutral position oil from the pump **P** flows to each spool and is dead ended. This generates sufficient pressure (about 20bar) to overcome the spring **E1** and oil flows across the bypass compensator spool assembly **E** to tank. Note that oil from the pump also flows into the 'auxiliary pump gallery' **1**. Oil from the 'bridge galleries' **3** is vented to tank via a groove in the main spool **S**.

Any load on the service ram **R** is held by the main spool **S**. Oil is also vented to tank from the load sense gallery **2** via the load sense drain regulator/relief valve **F** (see below).

#### Spool at point of operating a service

Pressure from the load on ram **R** enters the bridge gallery **3** via the service port **4**. Compensator check valve **H** is held down on its seat preventing the load moving. At the same time the isolator spool **U** lifts and allows oil from the auxiliary pump gallery **1** to flow into the load sense gallery **2**. Oil pressure builds in gallery **1** and the bypass compensator spool **E** begins to close under the action of the oil and spring (**E1**) pressure. This causes the pump pressure to rise to a new value as follows:

Pump pressure = Pressure in load sense gallery **2** + pressure from spring **E1**.

When the pressure in load sense gallery **2** reaches the load pressure, isolator spool **U** moves down and closes off the auxiliary pump gallery **1** from load sense gallery **2**. If the load pressure subsequently rises or falls, the isolator spool moves due to pressure imbalance and maintains the pressure in the load sense gallery **2** at the same pressure as the load pressure. The pressure in the load sense gallery **2** always

bleeds to tank, again causing pressure imbalance and the isolator spool to move, allowing the pressure in the gallery to be 'topped up'. This ensures that 'pressure balance' is always maintained.

It must be noted that the load sense gallery **2** is connected to all load sense valves (one for each service). The pressure in the gallery **2** will always be equal to the highest load from any of the backhoe services. The maximum load sense pressure is regulated by the load sense drain regulator/relief valve **F** (see below).

#### Spool fully operating a service

As the spool **S** is moved further oil from the pump is diverted into the central gallery **5**. If the pump pressure has risen sufficiently (to a pressure equal to the load + spring pressure **E1**) then check valve **H** moves up off its seat and allows oil to flow into bridge gallery **3**, and out to the ram **R** via service port **4**. Exhaust oil from the other side of ram **R** is diverted to tank.

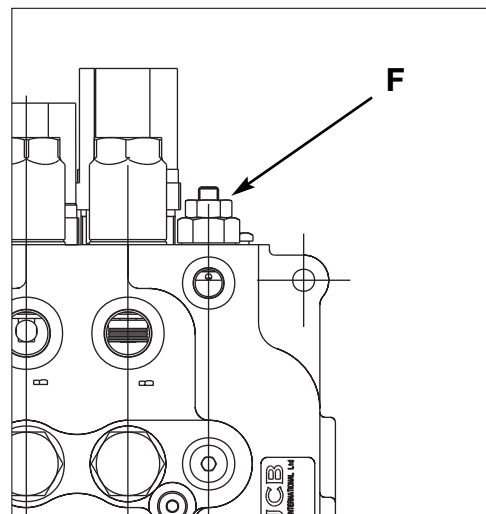

## Excavator Valve

### Precision Control (Servo)

\* (Machines up to serial no. 931159)

#### Hydraclamp Valve Operation

When the backhoe is being used for excavating duties, the kingpost assembly must be 'clamped' to the sideshift rearframe.

The hydraclamp control valve assembly (items **G**, **D** and **C**) is positioned in the front face of the excavator valve block and is connected directly to the parallel gallery **B**. The valve operates in conjunction with solenoid valve **E** located in the bottom of the excavator valve block.

#### 1 - Clamps Pressurised

When the hydraclamp switch **A** is in the OFF position (not pressed), the solenoid valve **E** is de-energised. The solenoid valve in this de-energised state blocks the exhaust path from the galleries **B** and **F** to the drain port **T** (tank).

When an excavator service is operated, pressure is generated in parallel gallery **B**, this pressurised oil moves piston **C** which pushes ball **D** off its seat against the force of spring **G**. The oil flows through restrictor **H**, past the ball and out to the hydra-clamps **62**.

#### 2 - Clamps Released - Precision Control Machines Only

To enable clamps release, the hydraclamp switch **A** must be in the ON position **and** an excavator service must be operated.

With the hydraclamp switch **A** in the ON position (pressed down), the solenoid valve **E** is energised. Pressure resulting from the operation of an excavator service moves piston **C** which pushes ball **D** off its seat.

With ball **D** lifted and the solenoid valve in its energised state, oil from the hydra-clamps is vented through the clamp valve and gallery **F** to the drain port **T** (tank).

Also, pressure resulting from the operation of an excavator service passes through restrictor **H**. The oil takes the path of least resistance and is vented via gallery **F** to the drain port **T** (tank).

Restrictor **H** ensures that only a small amount of oil from gallery **B** is dumped back to tank.

#### 3 - Clamps Locked Up

If no service is being operated, pressure in the parallel gallery falls to that of the neutral circuit and the force of spring **G** is sufficient to keep the ball **D** seated. Pressure is therefore trapped in the line to the clamps, maintaining the excavator end in a securely clamped condition.

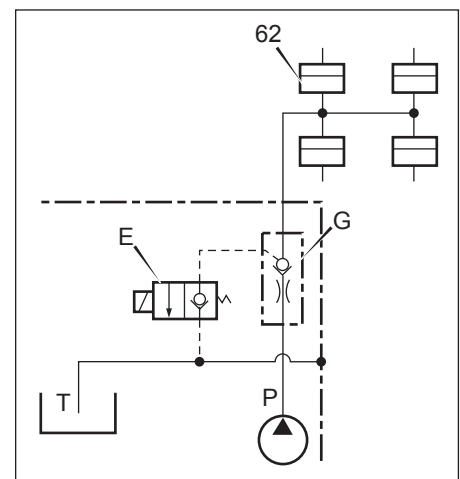
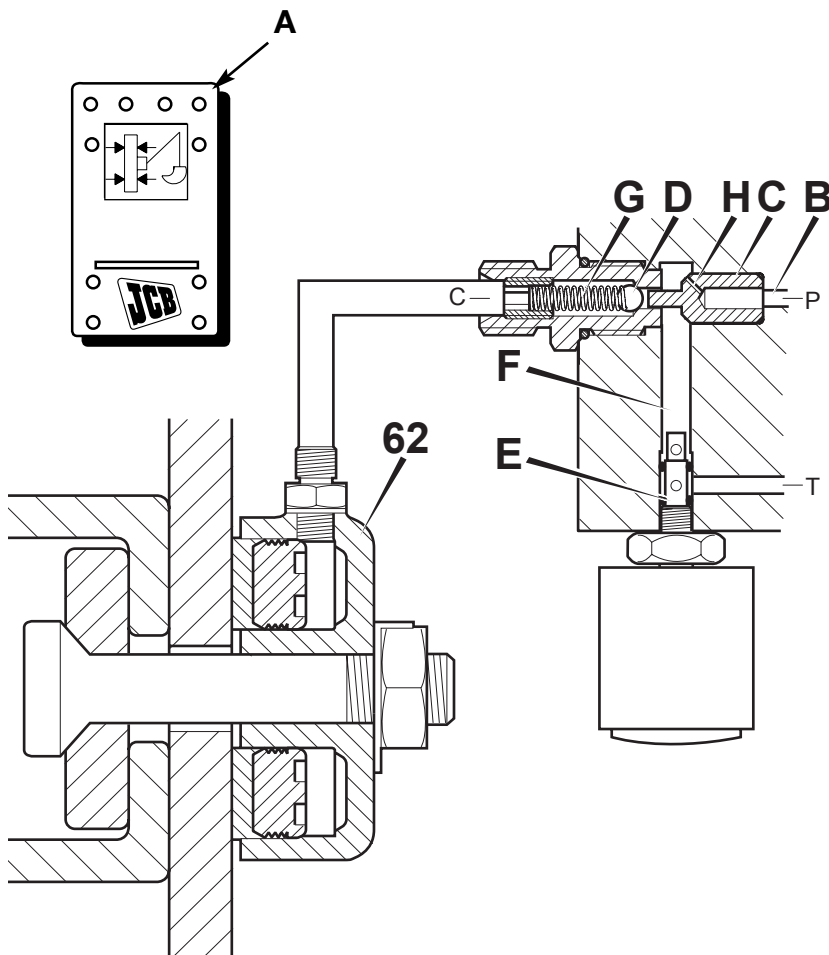

A402930

**Excavator Valve**

**Precision Control (Servo) (continued)**  
**(Machines from January 2003)**

In the interest of machine efficiency and consistent backhoe operation the excavator valve is of a closed centre design and incorporates pressure compensating valves **F**, for each service.

These features enable the valve to operate as follows:

**No service selected (all spools in neutral)**

Oil from the loader valve high pressure carry over enters the excavator valve at the inlet port **A**. Oil flows across the flushing valve spool assembly **B** and returns to tank from the outlet port **C**.

**Servo Spool Actuation**

When a service is operated servo pressure from the joystick control valve acts on the end of the relevant service spool **D** and displaces the spool proportionally against the force of the centering spring **E**, allowing the oil to flow to move the load. When the servo pressure on the end of the service spool is reduced the force of the centering spring overcomes the servo pressure and the service spool will move back proportionally to the central neutral position.

**When a Service is Selected**

When one or more services are selected the pressure compensator valves **F** detect the service generating the highest pressure. This causes the flushing valve spool **B** to close and allow pump flow to the spools and service ports at sufficient pressure to move the load. Load hold check valves **G** prevent the load falling back if the load pressure is greater than the pump pressure. The closed centre design ensures consistent service operation regardless of load.

For a full description of spool and pressure compensator valve operation see **Load Sense - Pressure Compensator Valve Operation**.

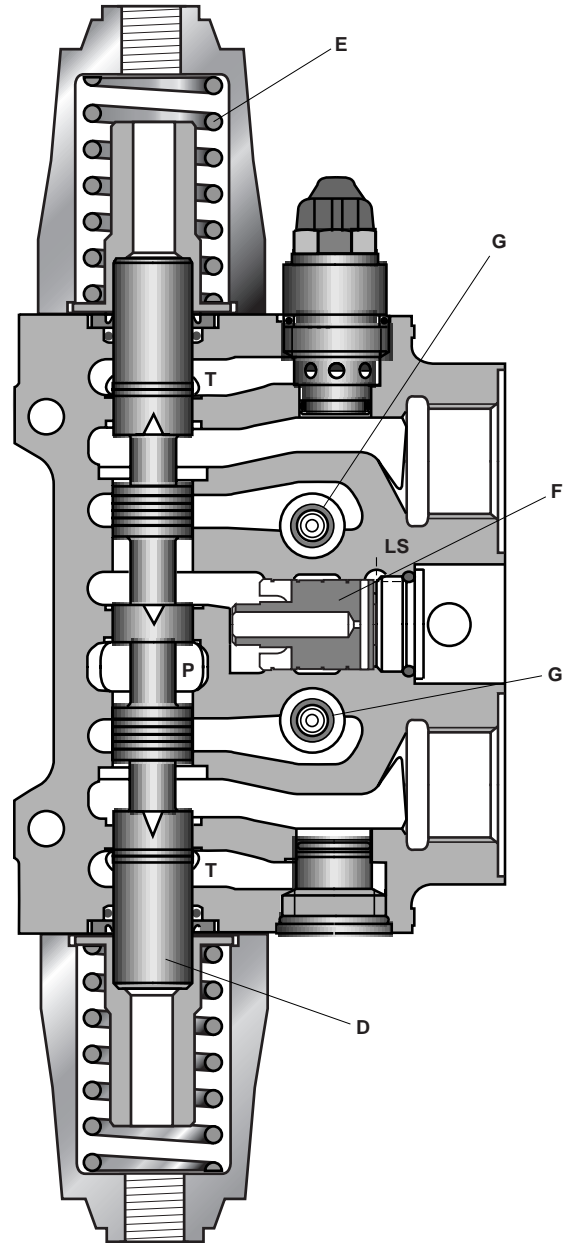

A405000

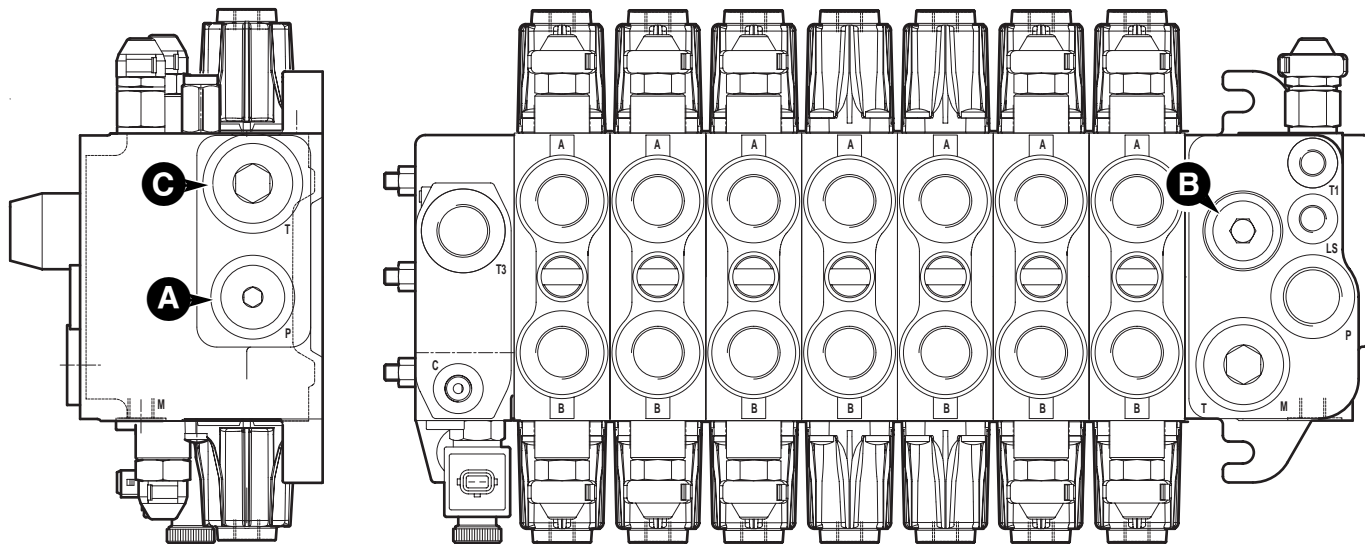

A403680