

DIFFERENTIAL SUPPORT

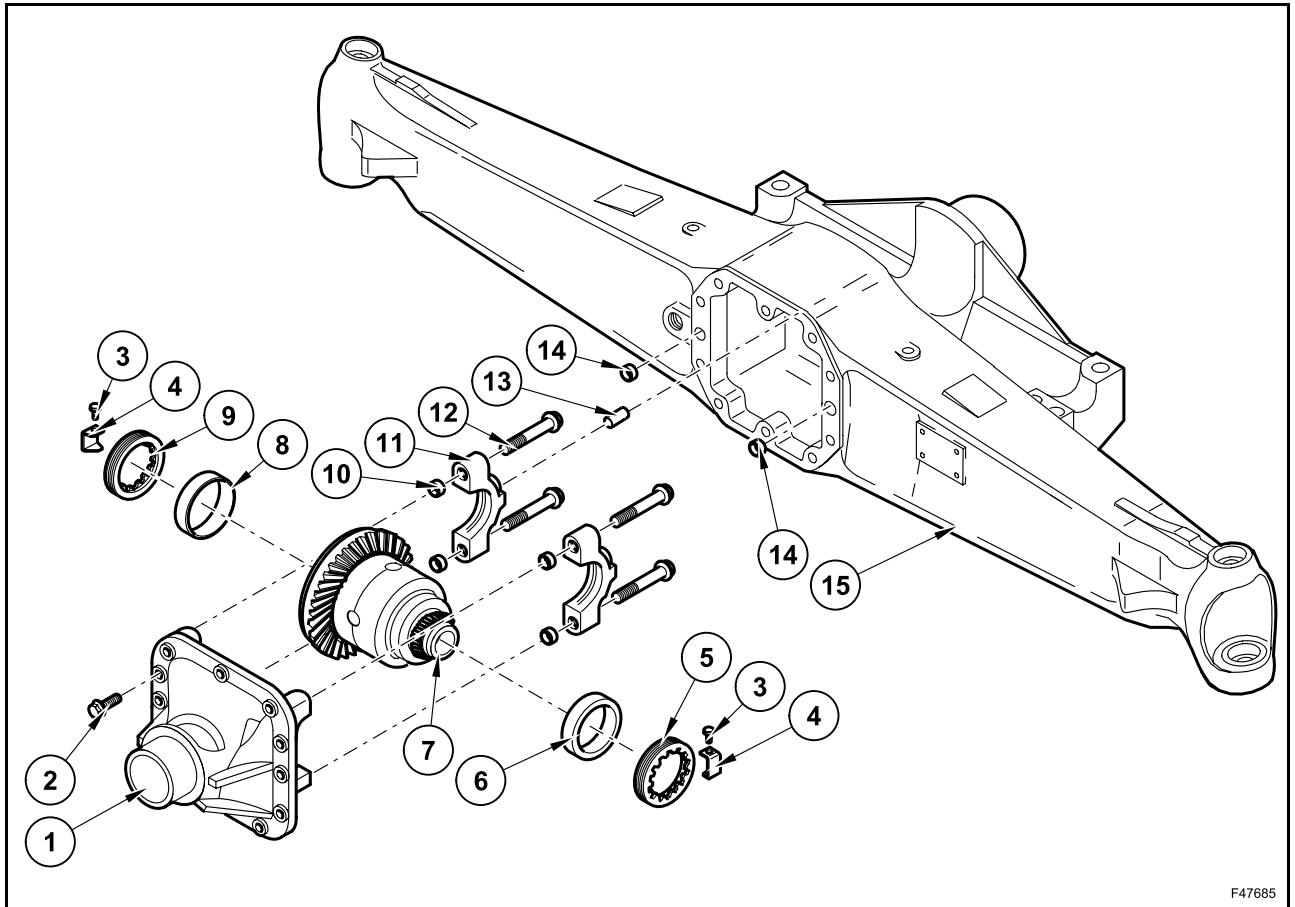

F47685

Disassembly

Drain the oil completely from the differential.

Loosen and remove the screws (2) of the differential support (1).

Remove the differential support (1) from the axle housing (15).



Support the differential support with a rope or other appropriate means.

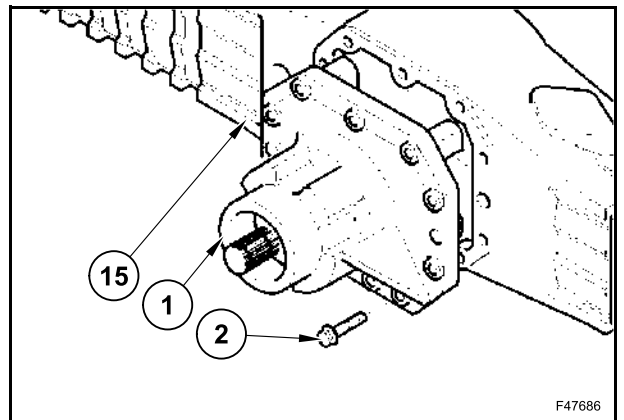

F47686

Measure the total starting preload F_{T0} of the bearings (pinion-ring gear system) using a dynamometer whose cord is wound on the splined end of the pinion shaft.

Note the value F_{T0} that is necessary for reassembling the bearings.

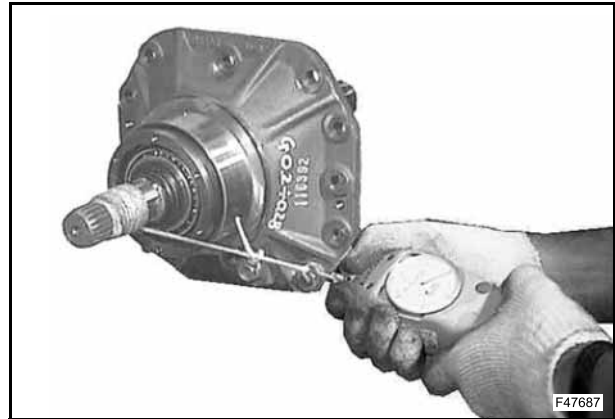

Loosen and remove the screws (3) to take out the two ring nut retainers (4).

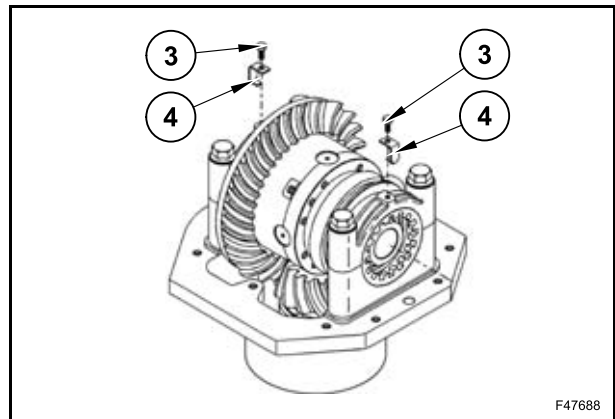

Before removing the screws, mark both half-supports and the differential support with permanent reference marks, to avoid exchanging them during re-assembly. Mark the area between the ring nuts (5) and (9) and the differential support (1) as well.

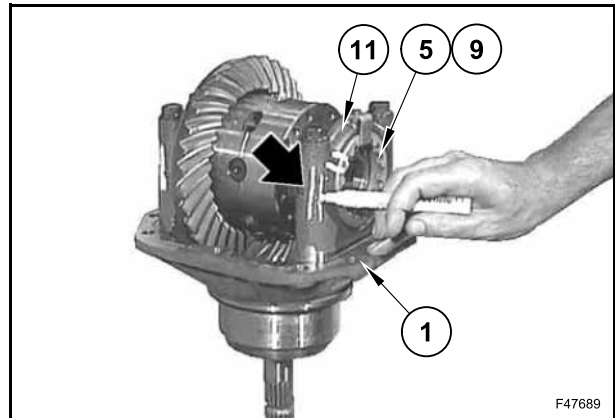

Loosen and remove the adjustment ring nuts (5) and (9) using tool **380000406** (A) and a wrench.

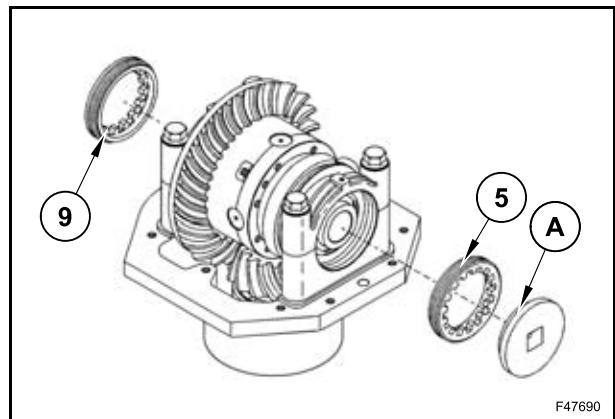

Loosen and remove the 4 screws (12).
Remove the half-supports (11).

NOTE: check that the bushings (10) remain in their housings.

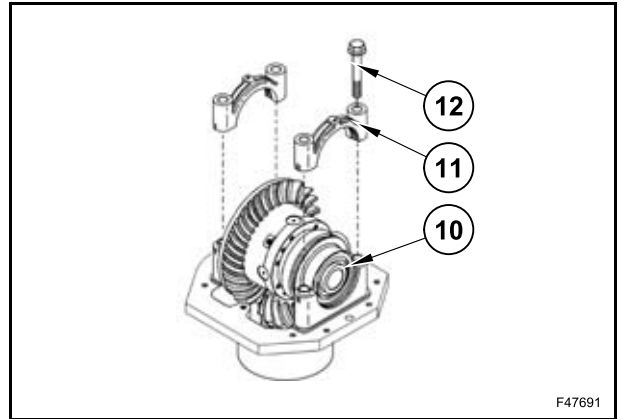

Remove the differential assy (7).

Remove the bearings (6) and (8) together with the differential assy.



Do not exchange the bearings in case they are replaced.

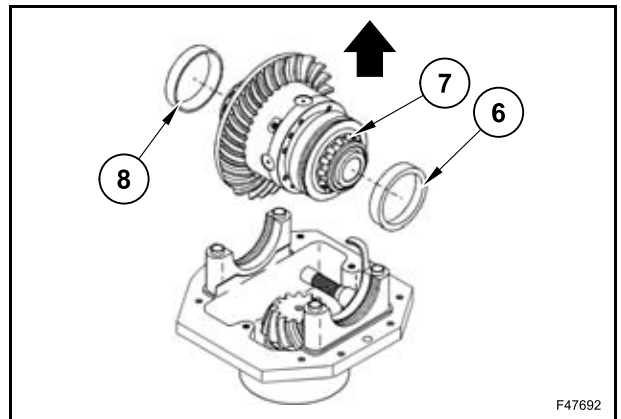

Assembly

Assemble the bearings (6) and (8) on the differential assy (7).



Do not exchange the bearings in case they are replaced.

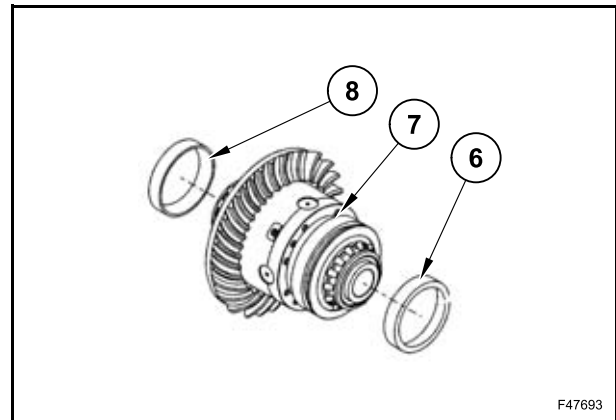

F47693

Assemble the differential assy (7) with bearings onto the differential support (1).



Check the correct assembly side of the ring gear.

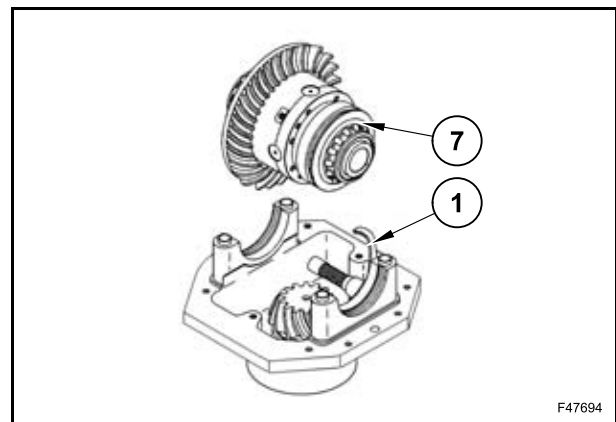

F47694

Move the differential assy so that the ring gear is placed against the pinion.

Check that all bushings (10) are in their housings and position both half-supports (11) in their seats, using the previously traced reference marks.

Lock both half-supports (11) with the fastening screws (12).

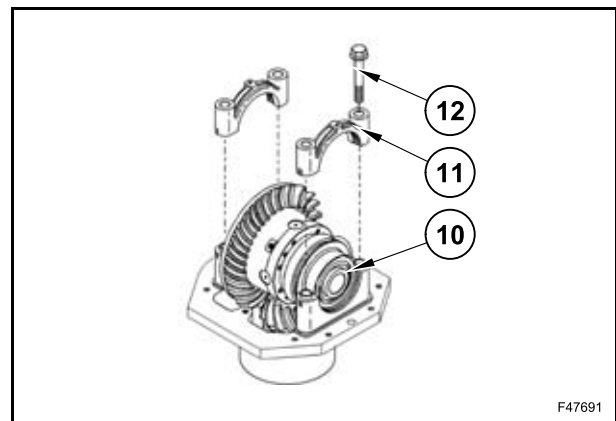

F47691

Assemble the adjustment ring nuts (5) and (9) to the differential support.

Tighten both ring nuts (5) and (9) with special tool **380000406**, till the backlash is eliminated and the differential bearings are slightly preloaded.

Check that the differential bearings are correctly seated.

If necessary, slightly knock with a rubber hammer.

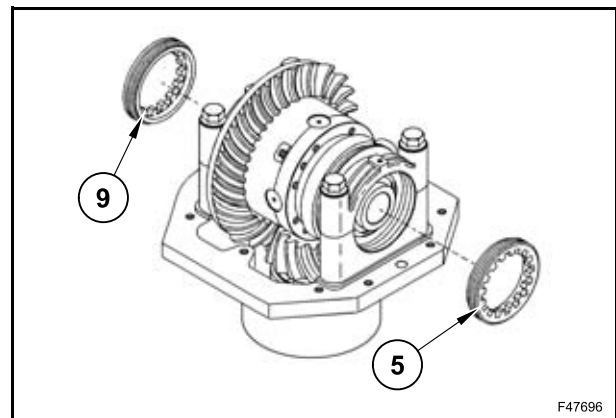

F47696

Position a magnetic-base dial gauge on the differential support, so that the feeler stylus touches the surface of one tooth of the ring gear with a 90° angle.

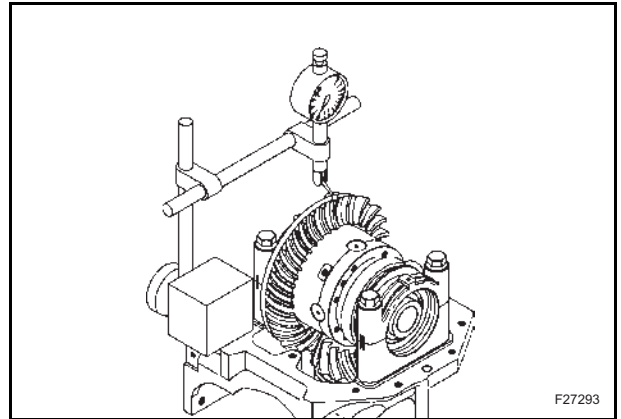

Lock the pinion and move the ring gear alternatively and note the ring gear backlash, measured with the dial gauge.

Repeat the operation on two or more points (teeth), rotating the ring gear, so that to obtain an average value.

Check if the measured backlash value is within the requested range:

0.18 ÷ 0.25 mm (0.0070 ÷ 0.0098 in)

Carry out the adjustment by operating on the ring nuts with the appropriate tool **380000406**.

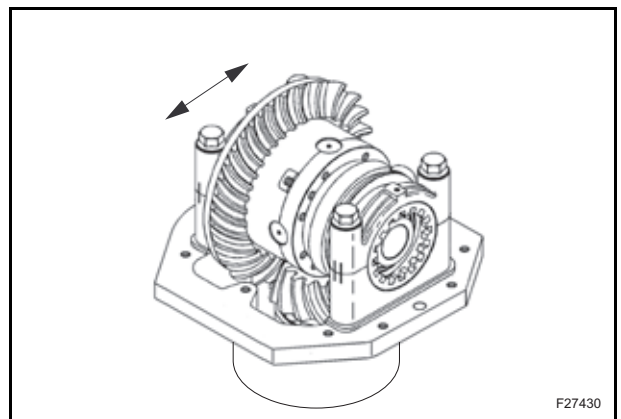

Loosen/tighten both adjustment ring nuts by approx. 30 degrees at a time, as indicated in the following step, then check the backlash.

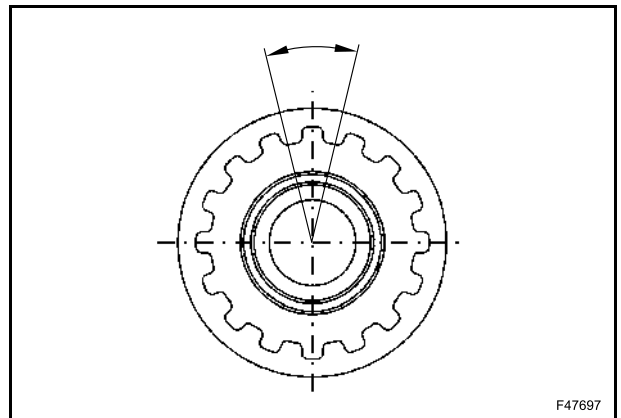

Adjust the ring nuts (5) and (9), remembering that:

- (A) - if the measured backlash is greater than the given tolerance range, unscrew the adjustment ring nut (5) and screw in the adjustment ring nut (9) by the same measure.
- (B) - if the measured backlash is lower than the given tolerance range, unscrew the adjustment ring nut (9) and screw in the adjustment ring nut (5) by the same measure.

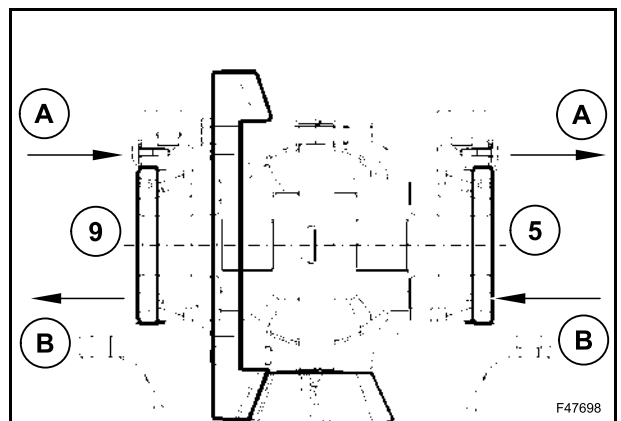

Once the adjustment of the pinion-ring gear backlash has been carried out, also check that there is a minimum preloading on the differential box bearings.

Repeat the whole sequence of the above mentioned operations until the indicated conditions are reached.

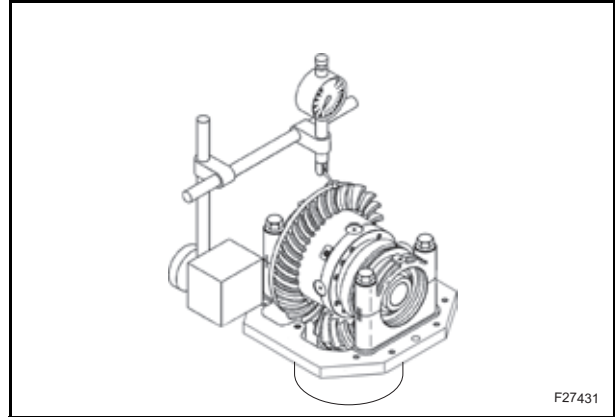

Once the pinion-ring gear backlash has been adjusted, if the bearings have not been replaced, measure the total preload F_{Tm} of the bearings (pinion-ring gear system), using a dynamometer whose cord is wound on the end of the splined pinion shaft.

The measured value F_{Tm} should be within the following range:

$$F_{Tm} = F_{T0} \div (F_{T0} + 10 (2.24 \text{ lbf})) \text{ N}$$



Use this method only if the bearings are already run in. Otherwise, see the procedure described below.

If the bearings have been replaced, measure the total preload F_{Tm} of the bearings (pinion-ring gear system), using a dynamometer whose cord is wound on the tool inserted on the pinion splined end.

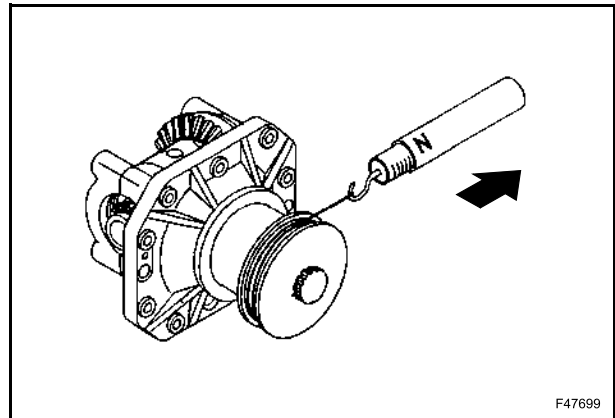

The total preload F_{Tm} is measured on the tool.

The measured value should be within the following range:

$$F_{Tm} = (F_{Pm} + 10.7 (2.40 \text{ lbf})) \div (F_{Pm} + 15.6 (3.50 \text{ lbf})) \text{ N}$$

- where F_{Pm} is the actual preload measured on the tool
- where D_m (gauge diameter) = 104.4 mm (4.11 in)

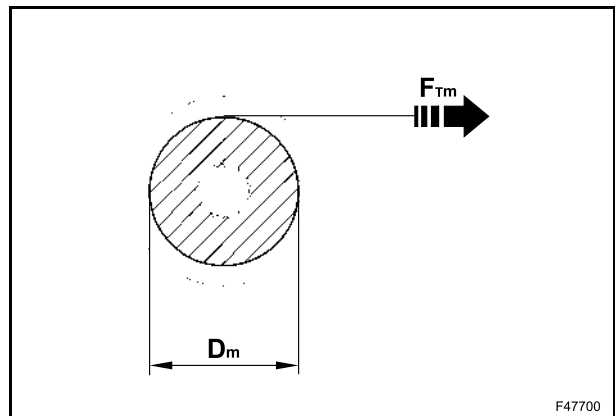

In case you do not use the prescribed tool to measure the total preload F_{Tm} , the reference diameter is the diameter of pinion shaft splined end. The measured value should be within the following range:

$$F_{Tm} = (F_{Pm} + 33.4 \text{ (7.50 lbf)}) \div (F_{Pm} + 50.1 \text{ (11.26 lbf)}) N$$

where F_{Pm} is the preload of the pinion bearings.

————— **⚠ WARNING ⚠** —————

This method is not precise with new bearings and therefore not recommended.

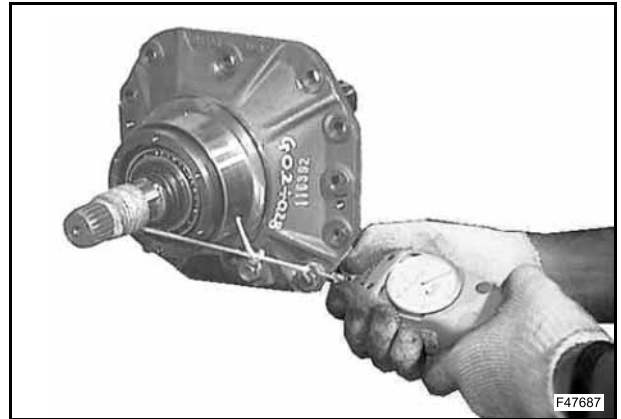

Once the pinion-ring gear backlash has been adjusted, as an alternative, it is possible to measure the total rolling torque (M_{Tm}) of the bearings (pinion-ring gear system) with a torque meter.

————— **⚠ WARNING ⚠** —————

All preloads must be measured without seal ring.

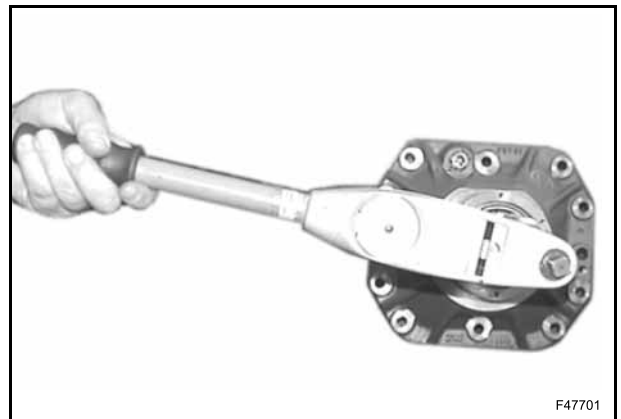

The total torque M_{Tm} should be within the following range:

$$M_{Tm} = (M_{Pm} + 0.58 \text{ (0.42 lbf·ft)}) \div (M_{Pm} + 0.87 \text{ (0.64 lbf·ft)}) Nm$$

where M_{Pm} is the preload of the pinion bearings.

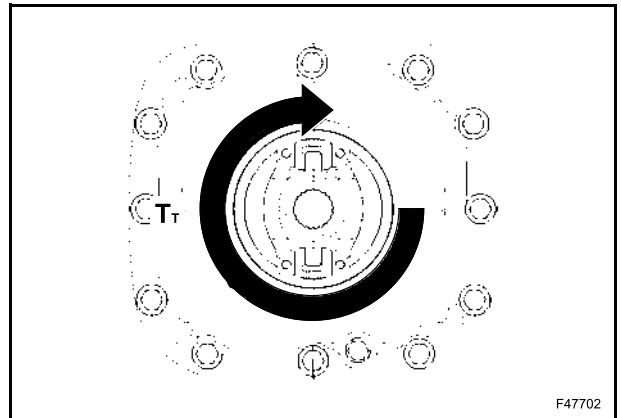

If the measurement is not within the requested range, check well the assembly of each component and operate on the adjuster ring nuts (5) and (9) of the differential support:

- (A)- if the total preload is lower than the given range, screw in both ring nuts (5) and (9) by the same measure, keeping the pinion-ring gear backlash value unchanged.
- (B)- if the total preload is higher than the given range, screw in both ring nuts (5) and (9) by the same measure, keeping the pinion-ring gear backlash value unchanged.

