

Pump - Remove (Machines Equipped with Pilot Controls)

- The hydrostatic pump assembly can be removed from the top and front of the cab and boom can be tilted forward for more access, refer to **ROPS - Tilt (E.34.A)** for the cab tilting procedure. To remove the hydrostatic pump assembly without tilting the cab forward.



CAUTION



Never enter or exit the skid steer unless the boom and attachment are resting on the ground or the boom is resting on the lock pins. M1113

- Lower the boom and bucket to the lowered position, resting on the ground or remove any attachments and raise the boom and rest on the boom lock pins, (1).

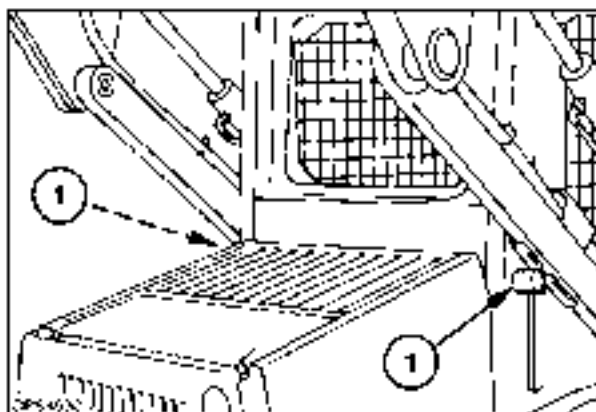

BS06B469 1

- Engage the parking brake.
- Stop the engine, turn the ignition key to the run position and operate the boom and bucket control pedals to relieve pressure in the boom and bucket circuits. Turn off the key.
- Securely block the skid-steer loader at, (1) and (2) with all four wheels off the ground, refer to Section 00 for more detailed information on properly supporting a skid-steer loader.



CAUTION



Always use the loader lift arms support pin when servicing the machine with the lift arms raised. Failure to do so can result in serious injury or death if the loader lift arms are lowered accidentally. M508

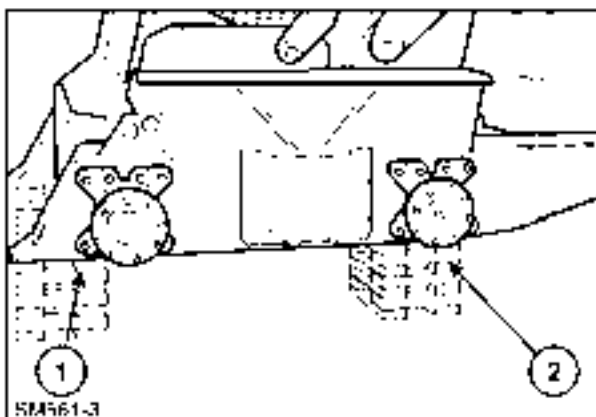

BS06J115 2

- Raise the operator's seat and latch in the raised position, (1).



CAUTION



Do not work under a raised seat and seat support unless the seat assembly is latched securely in the raised position. M1153

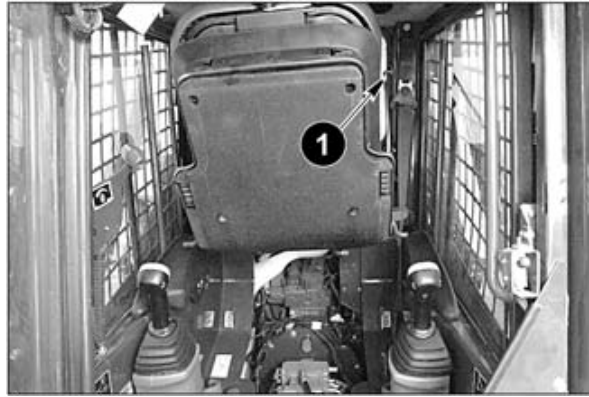

BD06K111_1 3

7. Remove the step shield to access the hydrostatic pump area. For more access, remove the right and left hydrostatic control handle assemblies.

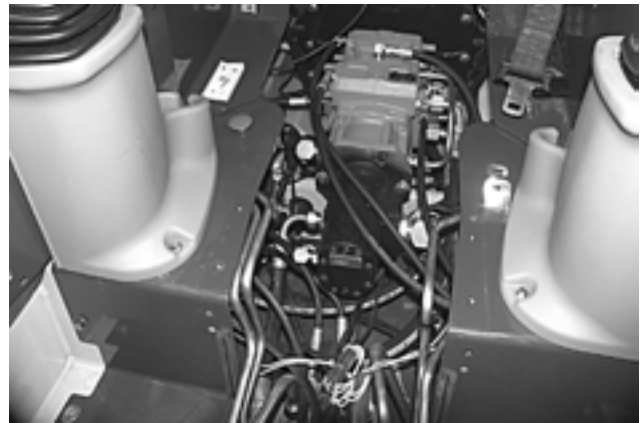

BD06K127 4

8. Relieve all pressure in the hydraulic and hydrostatic systems.



CAUTION



Never loosen any hydraulic lines or fittings without first having the boom in the completely lowered position (on the ground) or resting solidly on the boom lock pins. Any attachment must be in the completely lowered position to relieve all pressure in that circuit. Failure to comply will result in death or serious injury. M1150

9. Draining the hydraulic oil reservoir is not required if the suction and return lines are capped to prevent loss of oil. If the hydraulic system requires cleaning, draining is required.
10. Drain the hydraulic reservoir. Loosen the return line clamp, (2). Remove the return line at, (3) and rotate the line into a suitable drain pan.

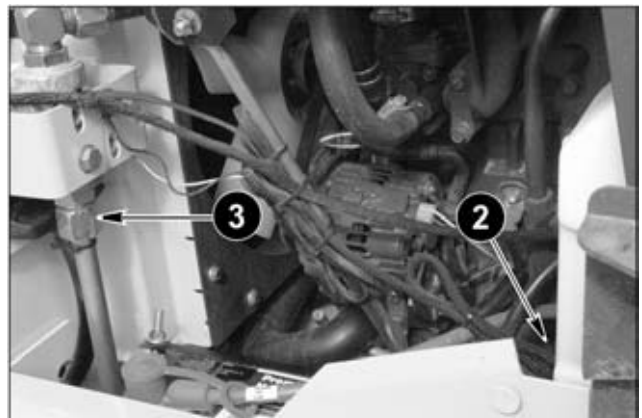

BD06K115_1 5

11. Disconnect and tag all the hoses from the equipment pump. Install caps and plugs on the fittings.

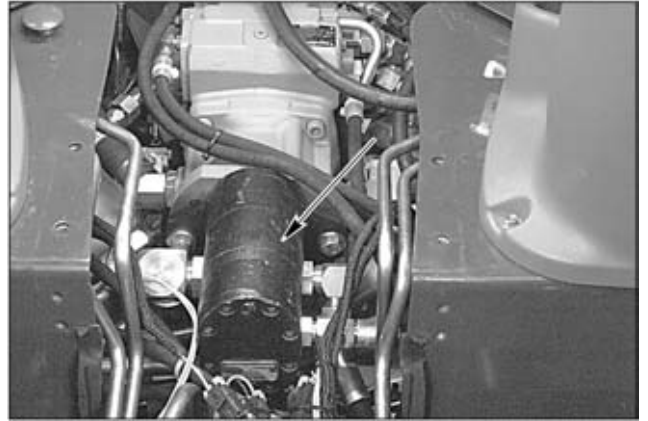

BD06K102_1 6

12. Support the equipment pump while removing the mount bolts as not to damage the drive coupling.
13. Loosen and remove the mount bolts, (4) from the equipment pump.

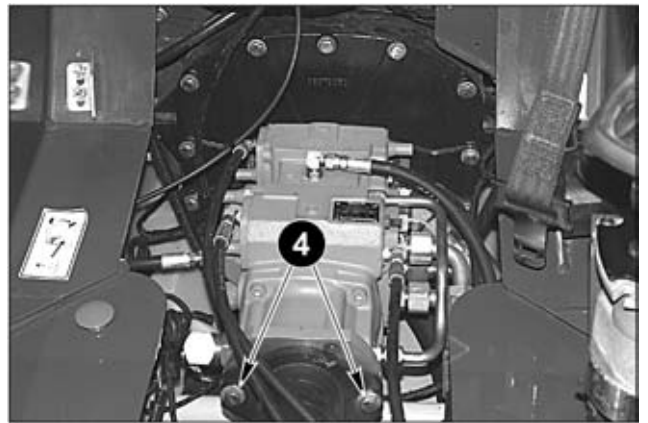

BD06K132_1 7

14. Remove the equipment pump from the chassis.
15. Disconnect and tag all the hoses from the hydrostatic pump. Install caps and plugs on the fittings.

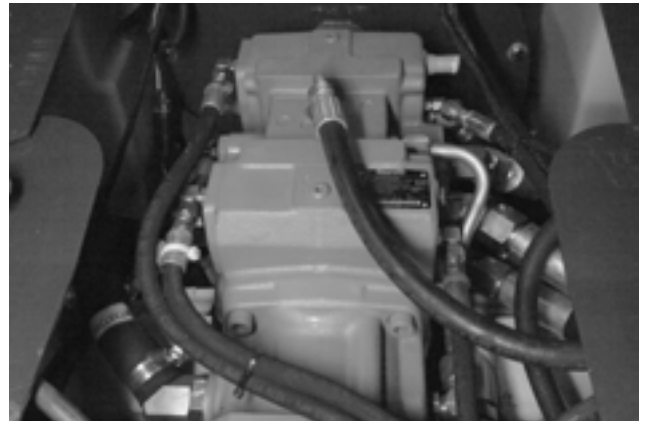

BD06K107 8

16. Connect acceptable lifting equipment to the hydrostatic pump. Support the hydrostatic pump.

17. Loosen and remove the two mount bolts, (5) from the support bracket located under the hydrostatic pump.

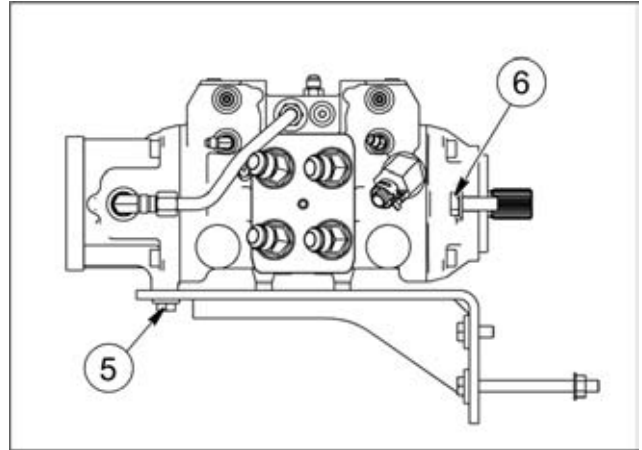

BS06K580_1 9

18. Loosen and remove the two mount bolts, (6) from the hydrostatic pump at the flywheel cover.
19. Move the hydrostatic pump away from the engine as far as possible.
20. Use the lifting equipment to remove the hydrostatic pump from the chassis.