

D350R0150

Fig. 4-108

Carefully read personal and machine SAFETY PRECAUTIONS at the beginning of this Manual

4.4.4 CHECK AND INSPECTION OF BRAKE DISCS PACK

Check the maximum warping of each disc (2) of the discs pack; it must be less than 0.03 mm. Check also the driven discs (1) conditions:

- the maximum thickness difference between the surfaces of sintered material cannot be more than 0.05 mm;
- the abovementioned surfaces should not have abnormal wear, due usually to foreign material contained in the oil or operating conditions with dry discs or pitted areas;

After completion of the above checks, assemble each discs pack (A) (8 driven discs and 7 driving discs) into the drum and check the total pack thickness (A) that should be 47.5 ± 0.5 mm under an hydraulic press force of $294 \div 392$ daN. In case of insufficient thickness, add one or more driving discs of normal or thinner type from the side indicated by the arrow.

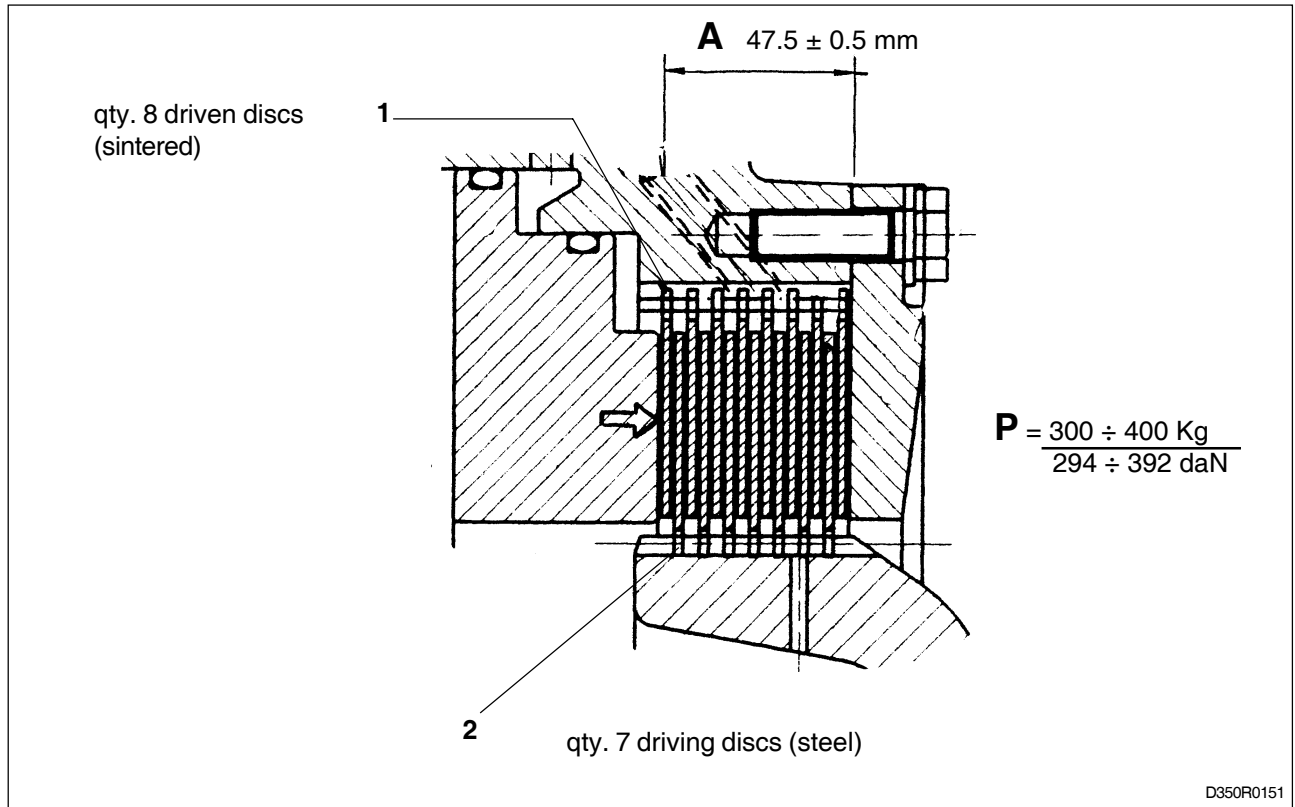

Fig. 4-109

DETERMINATION AND CHECK OF BRAKE DISCS PACK

Take dimension A with an hydraulic press force P, selecting suitable disc thickness (1 and 2).

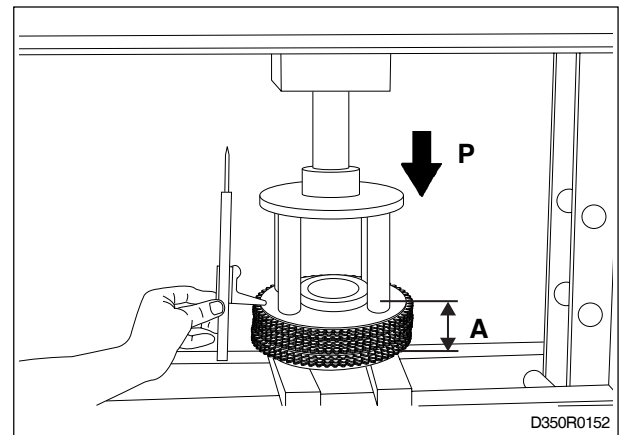

Fig. 4-110

Quantity of brake discs and thickness

- 1 - Driven (sintered) Qty. 8 discs, thickness: 3.8 , 3.9 mm
- 2 - Driving (steel) Qty. 7 discs, thickness 2.1 , 2.4 mm

4.4.5 SUPPORT ASSEMBLIES (Removal/Disassembly)

Removal of left-hand support



WARNING

Lift and handle heavy items with lifting means of suitable capacity. Make sure the load is held up by suitable slinging and hooks.

Remove the fuel tank as previously described in this manual. Remove the hydraulic motor as illustrated.

Remove all internal piping bound to the left-hand support.

Remove the fitting indicated in Fig. 4-113 because it would prevent pulling the support out of its seat.

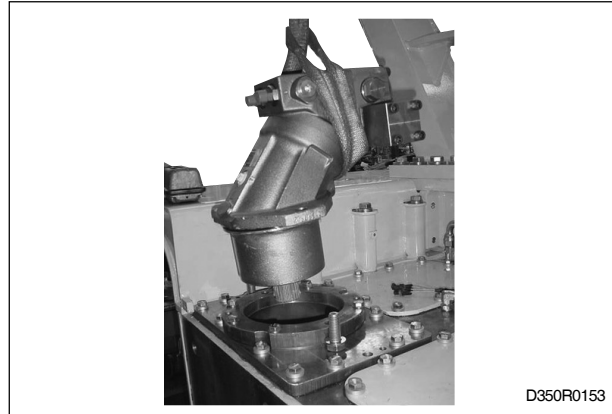

Fig. 4-111



Fig. 4-112

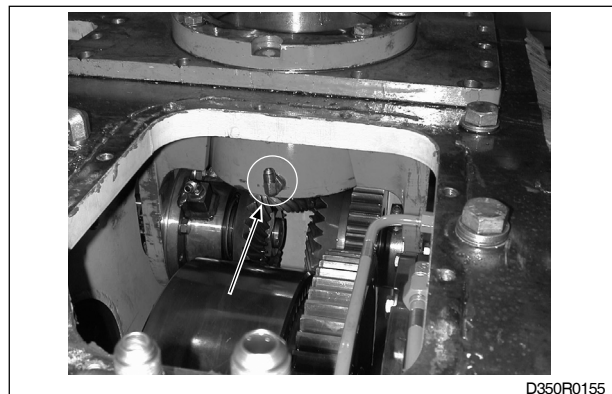

Fig. 4-113