

Coolant Fill Procedure (Optional)

NOTE – Filling the cooling system using the KL5007NAV Coolant Management Tool is the recommended procedure. However, in some cases, this tool may not be available, and the following gravity-fill method can be used instead.

NOTE – The following procedure is a more detailed version of the instructions found on Product Graphic 3871148C2, found on the vehicle.

1. Open any shutoff valve in the heater circuit, intransit heat circuit, or Auxiliary Power Unit (APU) circuit (not shown).
2. Close drain valve (or install quick-connect fitting) on Low Temperature Radiator (LTR) (Figure 6, Item 2).
3. Close drain valve on high-temperature radiator (HTR). This is not necessary if drain valve has been replaced with a quick-connect fitting (Figure 6, Item 2).
4. Turn ignition switch to the ON position (without starting vehicle). This opens the electrically-actuated LTR coolant flow valve (not shown).

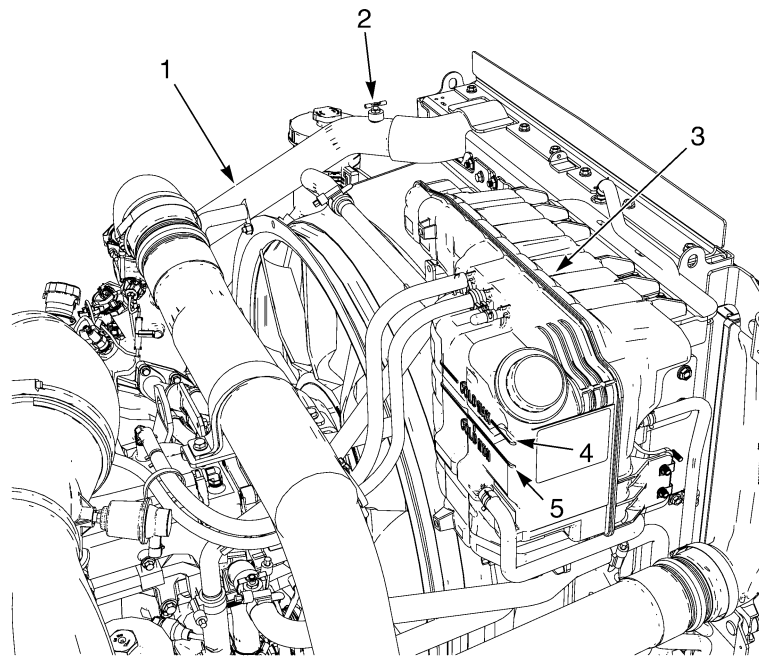

g1204116

- | | |
|------------------------------------|--------------------|
| 1. UPPER RADIATOR HOSE
ASSEMBLY | 3. DEAERATION TANK |
| 2. COOLING SYSTEM VENT VALVE | 4. COLD MAX LEVEL |
| | 5. COLD MIN LEVEL |

Figure 7 Deaeration Tank

5. Fully open cooling system vent valves.

NOTE – If the vehicle cooling system has been flushed with water prior to filling, use a portion of undiluted coolant concentrate to assist in achieving a 50/50 mixture after filling, or use a 75/25 mixture for the fill process.

6. Remove deaeration tank cap and pour a 50/50 mixture (75/25 if it has been flushed with water) of Extended Life Coolant concentrate and demineralized or distilled water into deaeration tank. A 50/50 coolant mixture will achieve a -37°C (-34°F) freeze point. A 53/47 coolant mixture will achieve a -40°C (-40°F) freeze point. The first pour should reach to the top of the deaeration tank fill neck.
7. Because radiator fills slowly, it is important to continue to top off system up to fill neck for 2 minutes following initial fill.

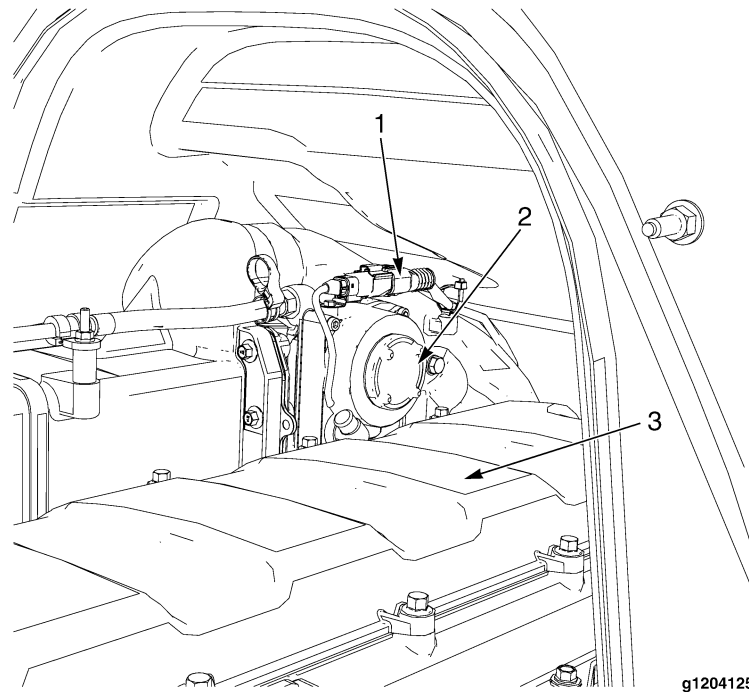

- | | |
|---|--|
| <ol style="list-style-type: none"> 1. ELECTRICAL CONNECTOR 2. EXHAUST GAS RECIRCULATION (EGR) VALVE | <ol style="list-style-type: none"> 3. Navistar 11 AND 13 LITER ENGINE |
|---|--|

Figure 8 Exhaust Gas Recirculation (EGR) Valve

8. Disconnect Exhaust Gas Recirculation (EGR) valve electrical connector.
9. When solid stream of coolant starts to pour from cooling system vent valves, close cooling system vent valves, and fill deaeration tank to the top.
10. Start engine and continue to add enough coolant to keep coolant level between COLD MIN and COLD MAX levels marked on deaeration tank. Replace deaeration tank cap tightly after adding make-up coolant for 2 minutes.
11. Run engine at governed speed until engine fan has fully engaged for 5 minutes. Do not exceed 104°C (219°F).

NOTE – The fan may not stay engaged for a full 5 minutes. If the fan cycles off and on, make sure total engagement time is at least 5 minutes. Do not exceed 104°C (219°F).

12. Turn off engine and connect electrical connector to EGR valve.

CAUTION

The truck MUST sit for 10 to 12 hours to cool to ambient temperature. Failure to do so could lead to component failure caused by air in the system.

13. Let engine completely cool to ambient temperature (10 - 12 hours). Check coolant level and concentration/freeze point with a refractometer and top off as needed using the appropriate concentration of water or concentrated coolant to achieve proper final coolant mixture.
14. Instruct operator to inspect and adjust coolant level as necessary, prior to daily operation.