

9. Unloading auger - Grain tank

9.2.5 Reconditioning of hydraulic cylinder

1. Carefully clean the outside of the cylinder.
2. Secure the cylinder in a vice with the hose connections downwards.

IMPORTANT: Avoid tightening the vice too hard, as this will deform the cylinder tube and ruin the cylinder.

3. Place a drip tray under the hose connections and move the piston back and forth several times to empty the cylinder of oil.
4. Dismantle the cylinder by unscrewing the cylinder top with a special spanner or pipe wrench.
5. Extend the piston.
6. Carefully clean all parts and inspect them for wear or defects.
7. Replace all seals supplied with the repair kit. New seals will be easier to mount if first softened by soaking in hot water.

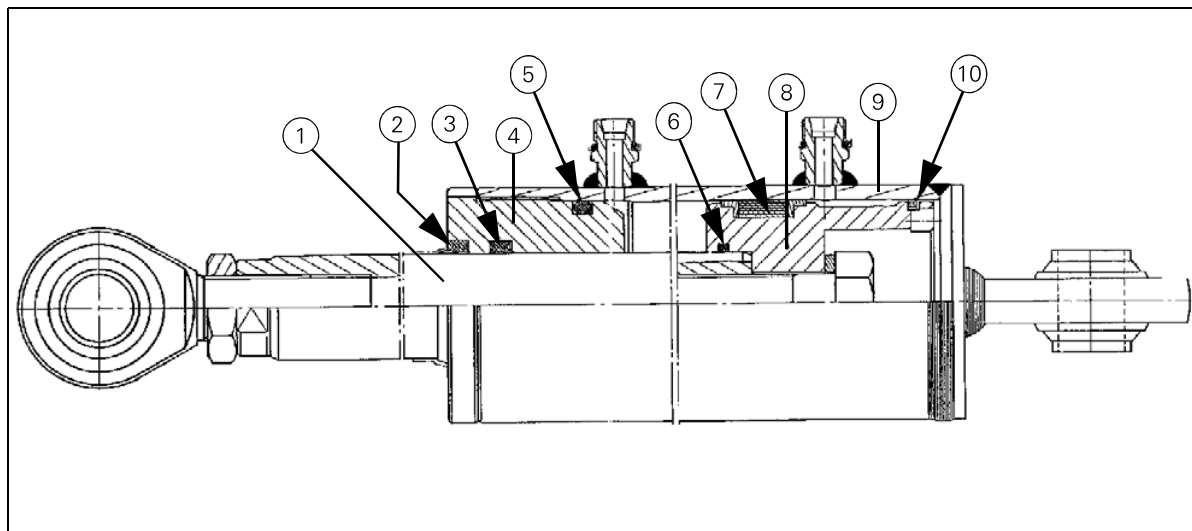

Fig. 11

69387

1. Piston rod
2. Scraper ring
3. Cylinder seal ring
4. Cylinder top
5. O-ring
6. O-ring
7. Piston seal ring
8. Piston
9. Cylinder
10. Braking ring

9. Unloading auger - Grain tank

9.3 Bottom auger and cover plate

9.3.1 Removal

1. Dismount the cover plate.
2. Dismount the cover plate.
3. Screw the bearing bracket off the bottom of the grain tank.
4. Dismount bolts in bearing flange on the right-hand side of grain tank.
5. Dismount the revolution sensor using the special tool as described in section 18.6 on page 585.
6. Dismount the locking screw and pull the clutch hub and belt pulley off the shaft.

IMPORTANT: *The puller legs must NOT pull on the belt pulley, but on the hub.*

7. Lifting the bottom auger up and forwards allows the telescopic joint to be disassembled and the auger to be lifted out of the grain tank.

9.3.2 Mounting

Follow points 1 - 7 in reverse order when mounting.
Please note:

IMPORTANT: *When the telescopic auger is reassembled, the transmission shaft must be assembled in the same spline again as described in section 9.1.2 on page 203.*

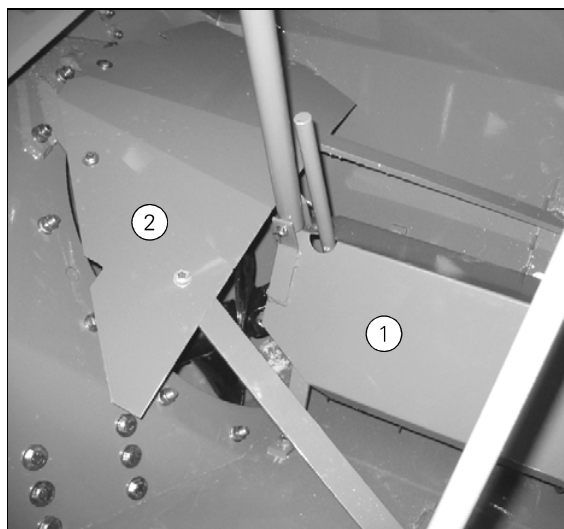

Fig. 12

90425

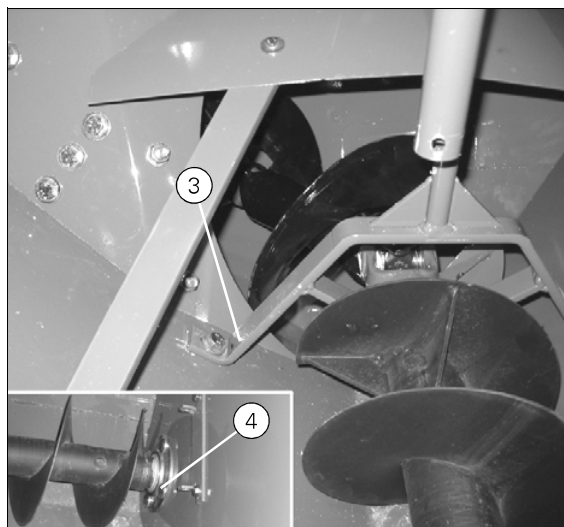

Fig. 13

90526_90528



Fig. 14

90732