

Fig 137.

- 17** Position the gasket.



Fig 138.

T009960

- 18** Position the cover and secure with the bolts. Tighten to a torque of 23Nm.

Note: The bolts are not all the same length.

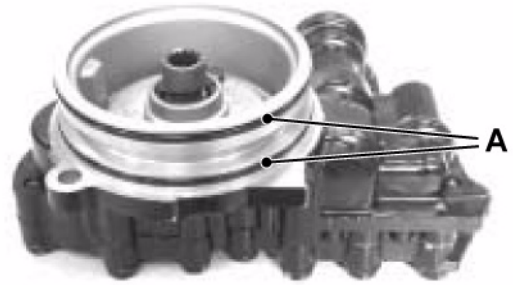

Fig 139.

T010270

- 19** Oil the O-rings **139-A** position them into the grooves of the pump.

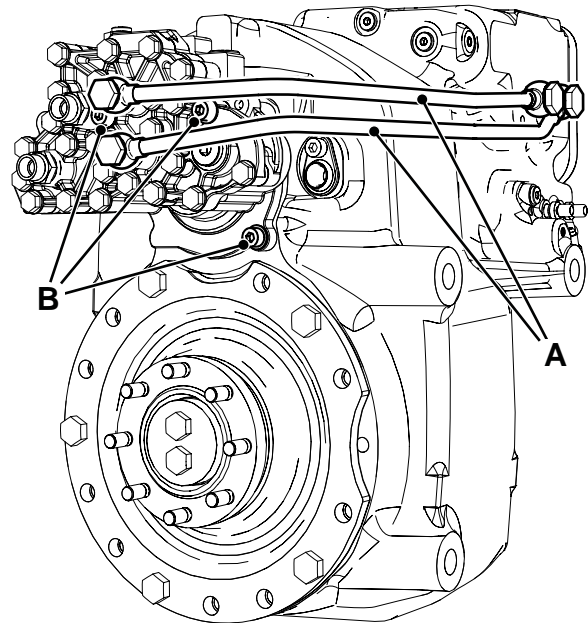

Fig 140.

T009120

- 20** Position the complete downshift interlock. and secure using the 3 x bolts **B**. Tighten to a torque of 23Nm.
- 21** Position the two pipes **A** and secure using bolts and sealing rings. Tighten the M14 bolt to a torque of 23Nm. Tighten the M16 bolt to a torque of 45Nm.



Section F - Transmission Drive Gearbox

Dismantling and Assembly

Page left intentionally blank

Propshafts

Removal and Replacement

Removal

Before removing propshafts always mark both companion flanges and also mark the sliding joints prior to removal.

Replacement

- 1 Upon reassembly, after lubricating sliding joints with JCB MPL Grease, align the shafts against identification marks previously made or, in the case of a shaft being renewed, use the manufacturer's alignment markings.
- 2 Apply JCB Threadlocker and Sealer to the threads of all flange bolts.
- 3 Retaining straps **C** stretch with use, therefore these straps must always be replaced with new ones.
- 4 The propshaft must have both ends exactly on the same plane as shown at **X**. The yokes must not be at right angles as at **Y** or at an intermediate angle as at **Z**.

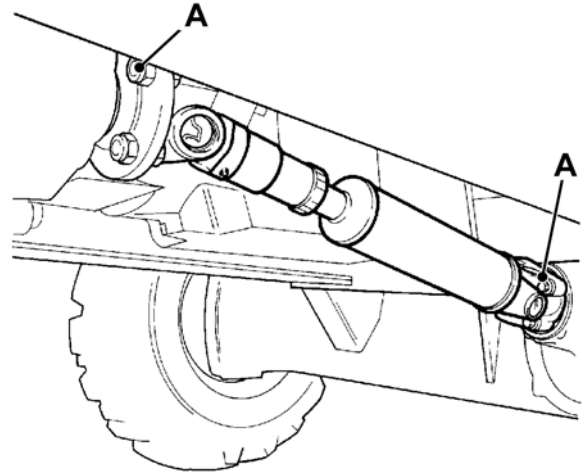

Fig 2. Rear

Table 1. Torque Settings

ITEM	Nm	lbf ft
A	75 -85	55 - 63
B	118	87

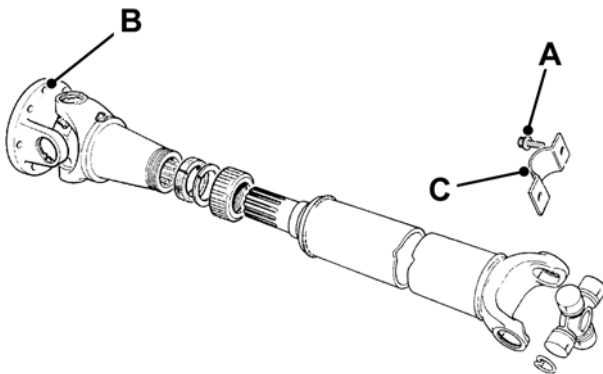
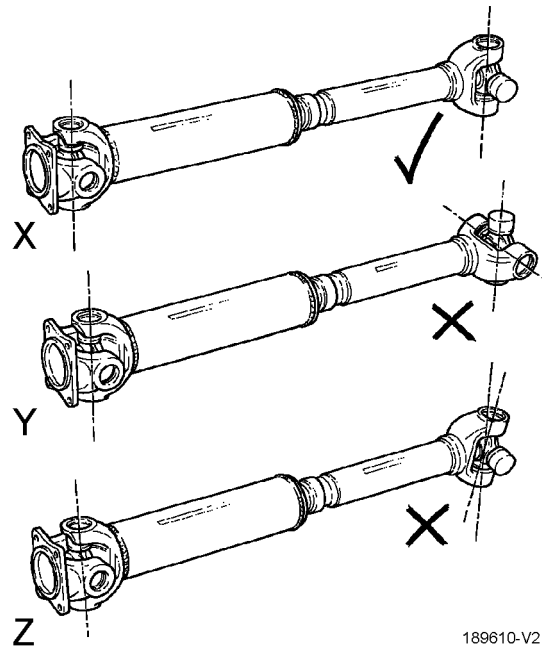

Fig 1. Front



189610-V2

Fig 3.



Section F - Transmission Propshafts

Removal and Replacement

Page left intentionally blank