

spool (17—Fig. 24) and housing (18) are available as a matched set only.

To disassemble the removed unit, first remove cap screws (24) and withdraw end plate (23), gear set (21), spacer (20) and drive link (19) as a unit. Unbolt and remove upper housing (5) and input shaft (1) as a unit. Withdraw the control spool and sleeve (17) as a unit from bottom end of housing. Remove Teflon discs (11), then push pin (10) and centering springs (9) out of sleeve. Carefully slide spool (splined end first) from sleeve (Fig. 25). Insert a bent wire through port in valve body and push plug (12—Fig. 24) from body, then remove check valve seat (14) using an Allen wrench. Remove check ball (15) and spring (16).

Inspect centering springs (9) for cracks or distortion and renew if necessary. Inspect spacer plates (20 and 23) and gear set (21) for wear or scoring. Parts should be renewed if measurable wear exists. Inspect control spool and sleeve and housing bore for nicks, scoring or wear. If any part is damaged, renew steering pump assembly. Renew all "O" rings and seals.

When assembling the unit, tighten check valve seat (14) to a torque of 17 N·m (150 in.-lbs.). Assemble spool in sleeve making sure spool rotates smoothly in sleeve. Align spring slots in spool and sleeve, then insert centering springs (two sets of three each) so arched center sections are together as shown in Fig. 25A. Insert pin (10—Fig. 24) into spool and sleeve assembly and install a Teflon disc (11) at each end of pin.

Install assembled control spool unit from bottom of valve body using a twisting motion. Do not allow sleeve to move beyond flush with machined surface of metering end of valve body.

Install upper housing (5) with input shaft (1) over splined end of spool and onto valve body. Tighten retaining cap

screws evenly to 25 N·m (220 in.-lbs.) torque.

Be sure pin slot in drive shaft (Fig. 26) is aligned with a valley of inner rotor to ensure correct timing of control sleeve. If drive slot is improperly aligned, steering unit will operate in reverse or "kick back" when hydraulic pressure is applied. Assemble drive link (19—Fig. 24), spacer (20), gear set (21) and spacer (22) onto valve body. Note that spacer (22) should be flush with outer surface of gears if drive link is properly engaged with control spool pin. Install end cover (23) and tighten retaining cap screws evenly to 17 N·m (150 in.-lbs.) torque.

MF245 Standard Models

23. OVERHAUL. All MF245 models except Orchard are equipped with the hydrostatic hand pump shown exploded in Fig. 27. The valve spool (22) and body (25) are available only as a matched set.

To disassemble the removed steering control valve assembly, install a fitting in one of the four ports in valve body (25),

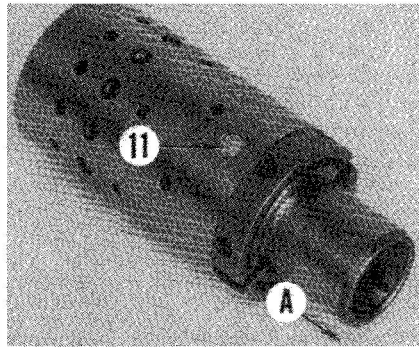

Fig. 25—View of control spool and sleeve assembly. Teflon discs (11) cover outer ends of internal pin. Withdraw spool from sleeve in direction of arrow (A).

then clamp fitting in a vise so input shaft (17) is pointing downward. Remove cap screws (39) and end cover (38).

NOTE: Lapped surfaces of end cover (38), commutator set (33 and 34), manifold (32), stator-rotor set (31), spacer (29) and valve body (25) must be protected from scratching, burring or any other damage as sealing of these parts depends on their finish and flatness.

Remove seal retainer (35) and seal (36), then carefully remove washer (37), commutator set (33 and 34) and manifold (32). Grasp spacer (29) and lift off the spacer, drive link (30) and stator-rotor set (31) as an assembly. Separate spacer and drive link from stator-rotor set.

Remove unit from vise, then clamp fitting in vise so input shaft is pointing upward. Place a light mark on flange of upper cover (9) and valve body (25) for aid in reassembly. Unbolt upper cover from valve body, then grasp input shaft and remove input shaft, upper cover and valve spool assembly. Remove and discard seal ring (10). Slide upper cover assembly from input shaft and remove Teflon spacer (16). Remove shims (12) from cavity in upper cover or from face of thrust washer (14) and note number

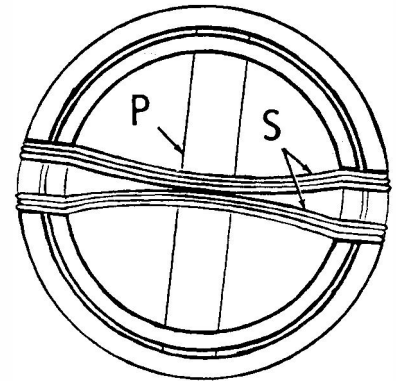

Fig. 25A—Schematic end view of steering control sleeve and spool showing correct assembly of centering springs (S) and drive pin (P).

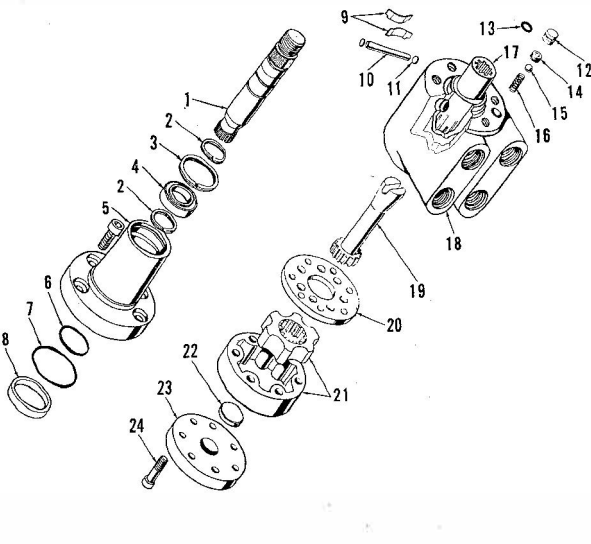

Fig. 24—Exploded view of Char-Lynn Orbital hydrostatic steering hand pump used on MF235 and MF245 Orchard models.

1. Input shaft
2. Snap rings
3. Snap ring
4. Bearing
5. Shaft housing
6. Quad ring
7. "O" ring
8. Bushing
9. Centering springs
10. Pin
11. Teflon disc
12. Plug
13. "O" ring
14. Ball seat
15. Check valve ball
16. Spring
17. Control spool & sleeve
18. Valve housing
19. Drive link
20. Spacer plate
21. Gear set
22. Spacer
23. End plate
24. Cap screw

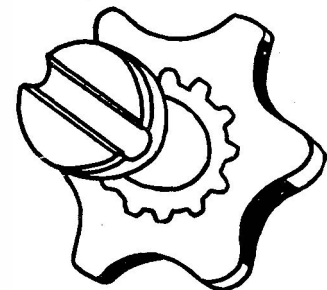

Fig. 26—When properly assembled, slot in end of drive link must align with valley of inner gear as shown to provide correct valve timing.