

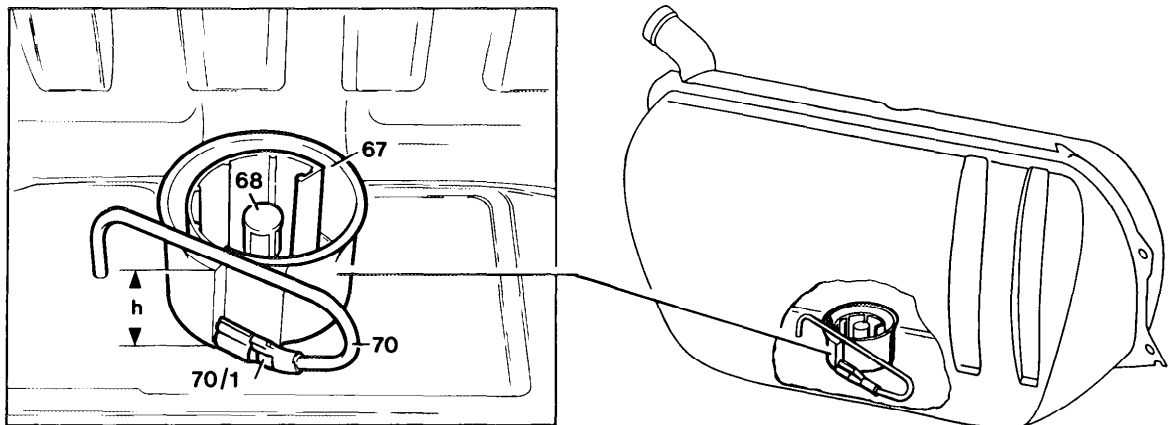

	Job No.
Function of fuel tank with splash pot	47 - 010
Function of fuel gauge sending unit	47 - 020
Function of fuel gauge sending unit - Turbodiesel	47 - 020
Function of fuel tank breather and vent	47 - 030
Function of fuel tank ventilation - Turbodiesel	47 - 030
Removal and installation of fuel tank	47 - 100
Removal and installation of fuel gauge sending unit	47 - 120

47-010 Function of fuel tank with splash pot



P47-0071-55

Model 201 with naturally-asprated engines

67	Splash pot
68	Fuel filter
70	Return line
70/1	Return nozzle

The sheet steel fuel tank is fitted with a splash pot (67). The purpose of this is to ensure that the engine is reliably supplied with fuel when the fuel level in the tank is low and when negotiating a lengthy series of curves.

When the fuel pump is running, the return fuel jet flows at a high speed out of the return nozzle (70/1) into the splash pot. In this way it draws fuel around the return nozzle into the splash pot as well.

The level of fuel (h) in the splash pot is maintained even if the fuel level in the tank drops below the height (h).

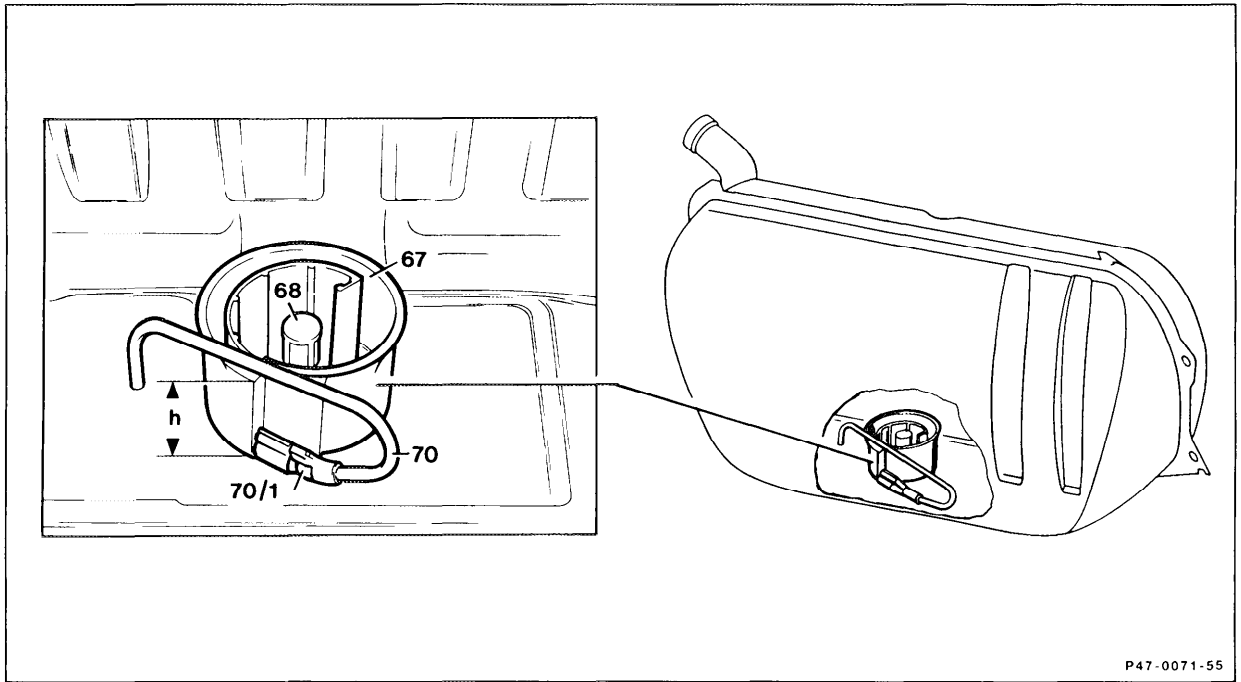

Model 201, 124, 126 with Turbocharged engines

67 Splash pot
68 Fuel filter

70 Return line
7011 Return nozzle

47-020 Function of fuel gauge sending unit

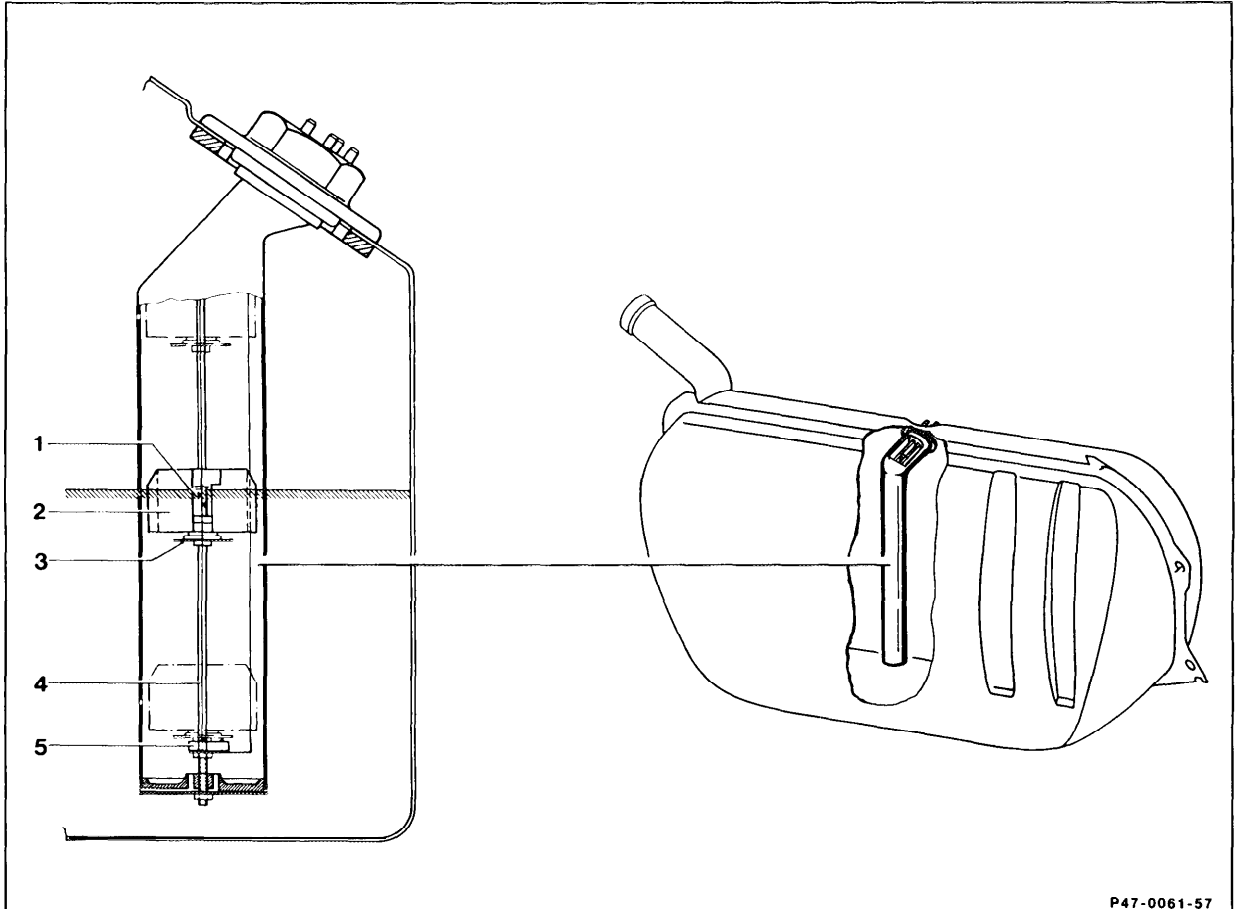

- 1 Wiper contact
- 2 Float
- 3 Contact plate
- 4 Guide and contact rod
- 5 Reserve warning contact

As the fuel level drops, the resistance is increased by the wiper contact (1). At the float (2), the voltage drops and the gauge needle in the instrument cluster moves back.

If the fuel level drops to the reserve quantity, the reserve warning contact (5) closes and switches ground to the reserve warning lamp. The reserve warning lamp lights up when the ignition is switched on (check function).

As soon as the engine starts, the lamp goes out provided there is more fuel in the tank than the reserve quantity.

Note

The reserve warning lamp shows a weaker light for the check function, and a stronger light to indicate reserve quantity.

Check fuel gauge (54-269).

Fuel gauge sending unit, Model 201

The installation angle has been modified from approx. 15° (off perpendicular) to approx. 5°. The instrument gauge has been adapted to the new sending unit position (refer to Group 54).

Repair instructions

The modified sending unit (5°) may also be fitted in place of the existing sending unit (15°), but not vice versa.

Standard implementation: July 1987

Vehicle ident No.

A 394 178

F 390 243

Modifications effective 09/88 (Model Care)

The fuel gauge sending unit has been modified at the flange and in its length such that it is valid for all fuel tanks of Model 201 effective 09/88.

47-020 Function of fuel gauge Sending unit - Turbodiesel

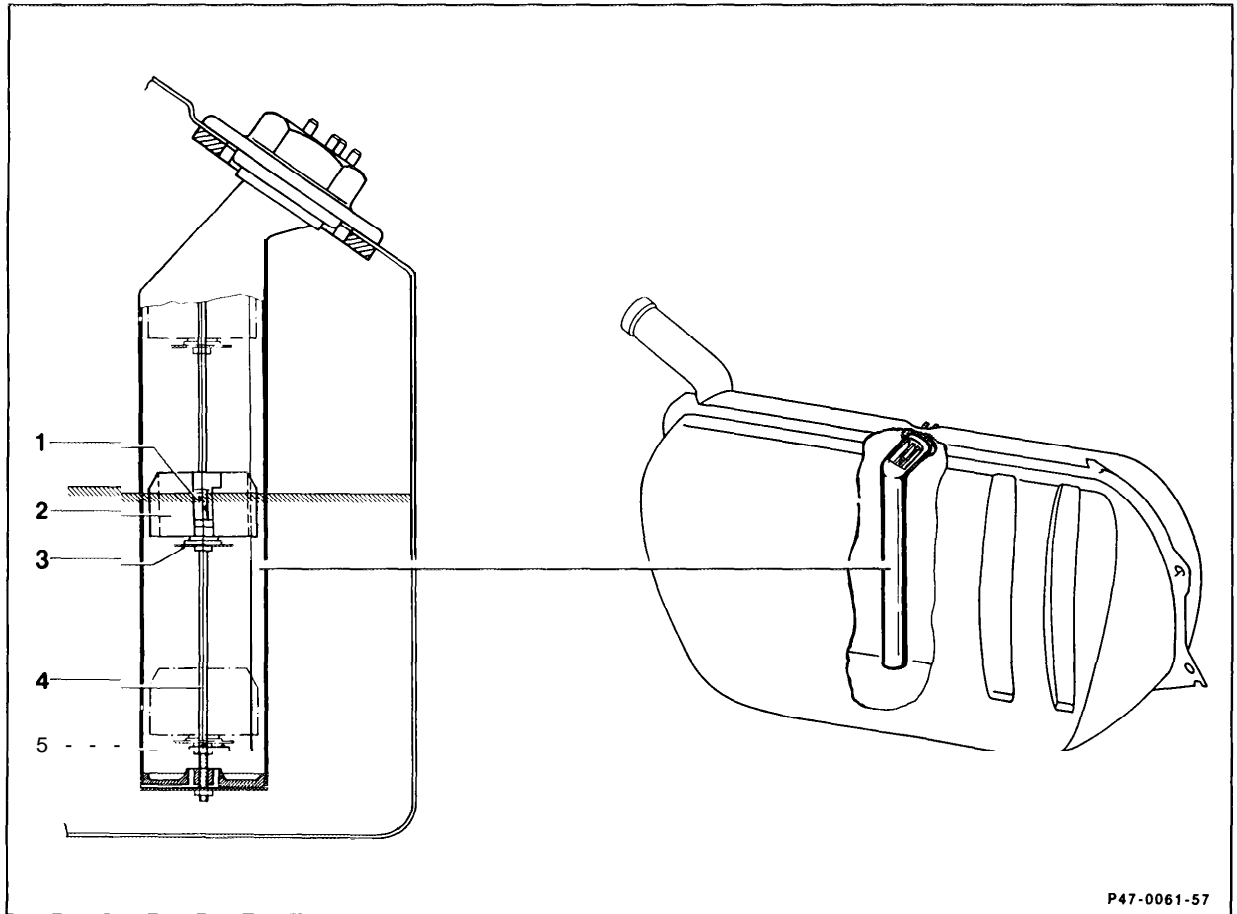

1 Wiper contact
2 Float
3 Contact plate

4 Guide and contact rod
5 Reserve fuel warning circuit

If the fuel level drops, the resistance is increased by the wiper contact (1) on the float (2), the voltage drops and the needle on the gauge in the instrument cluster moves back.

If the fuel level drops to reserve quantity, the reserve warning contact (5) closes and switches ground to the reserve warning lamp. The reserve warning lamp lights up if the ignition is switched on (indicating function). As soon as the engine is running, it goes out provided there is more fuel in the tank than the reserve quantity.

Note

The reserve fuel warning lamp shows a weaker light for the indicating function and a stronger light for the reserve quantity.

Check fuel gauge (54-257).

47-030 Function of fuel tank breather and vent

Filler cap

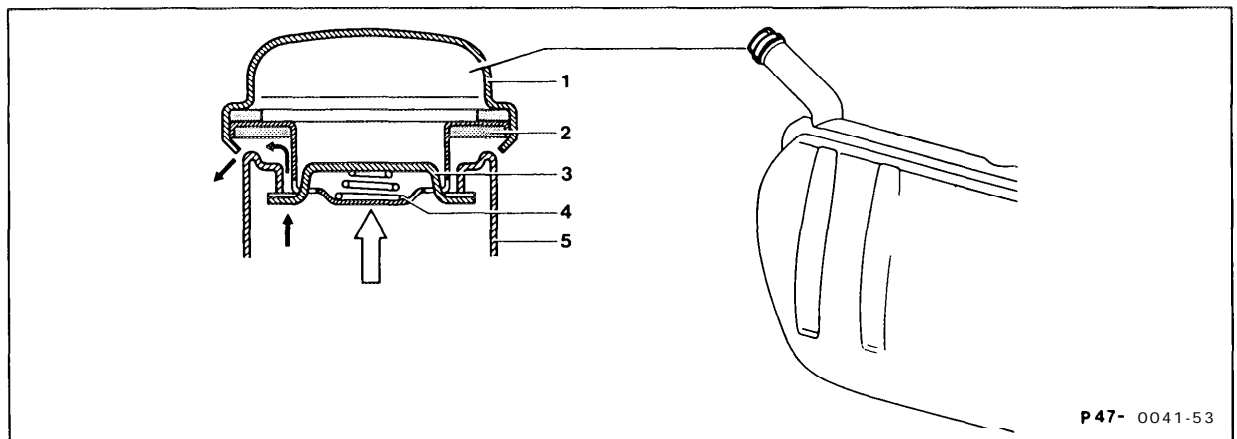

All models

- 1 Filler cap
- 2 Sealing ring
- 3 Locking bar
- 4 Compression spring
- 5 Filler neck

The fuel evaporation gases escape through the filler cap at a pressure of 100-300 mbar gauge. This only occurs, if, for example, the passage in the vent line from the fuel tank is not clear. If the system is operating properly, an overpressure of up to 50 mbar may be present in the fuel tank.

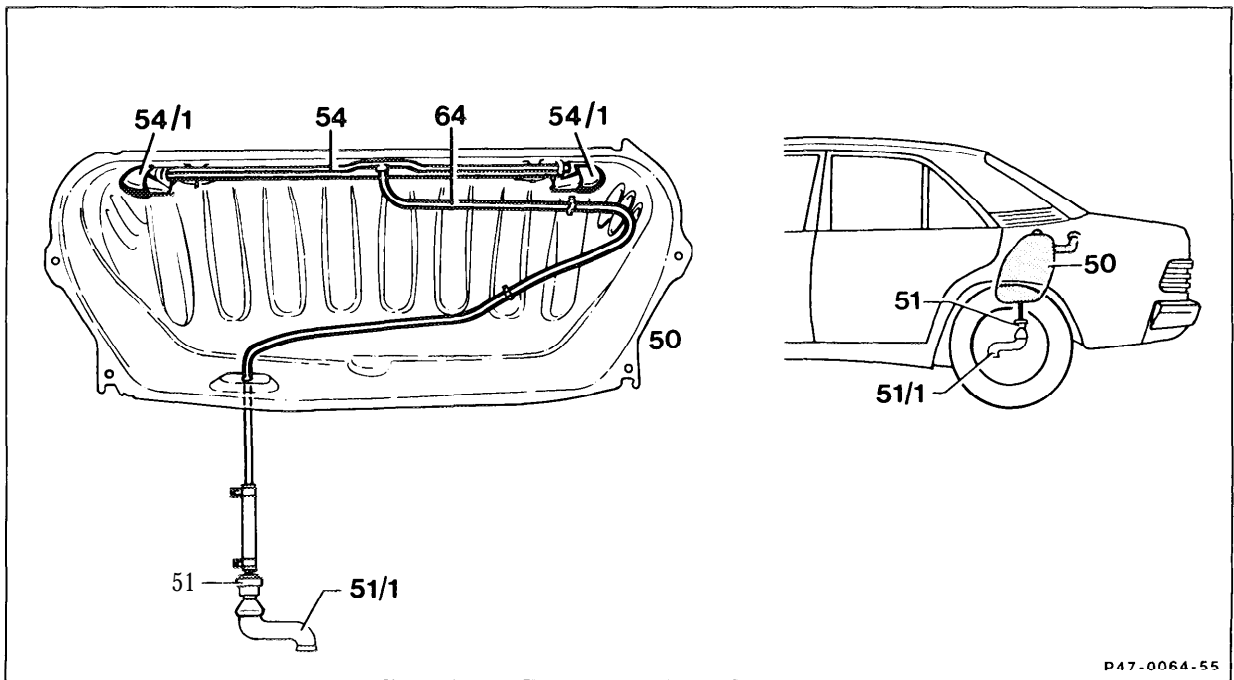

D47-0064-55

- 50 Fuel tank
- 51 Vent valve
- 51/1 Protective rubber boot
- 54 Central pipe
- 54/1 Siphon breaker
- 64 Vent line

The vent system consists of a central pipe (54) with an siphon breaker (54/1) at each end. The siphon breakers prevent fuel escaping along the vent line. The vent line (64) runs from the central pipe to the vent valve (51).

If an overpressure of 30-50 mbar is reached in the fuel tank, the vent valve (4) opens and the fuel vapors flow to the charcoal canister.

- 1 Compression spring
- 2 Valve housing
- 3 Spring plate
- 4 Vent valve
- 5 Valve plate
- 6 Air admission valve
- 7 Connection fitting

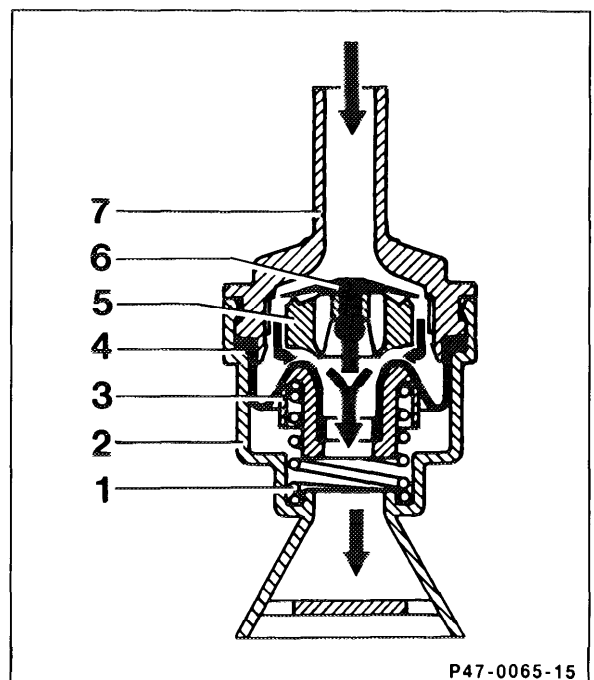

P47-0065-15

If a vacuum of 1-1 6 mbar is produced in the fuel tank, the air admission valve (6) opens.

The protective rubber boot at the end of the vent valve prevents dirt and splash water entering the vent valve.

Standard implementation:

Model	Vehicle ident No.	
	April 1986	May 1986
201	A 296211	F 227064

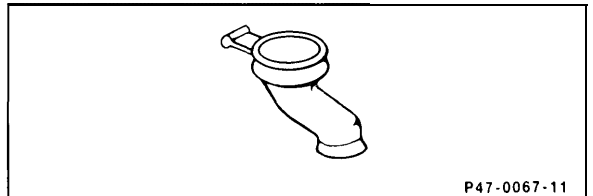
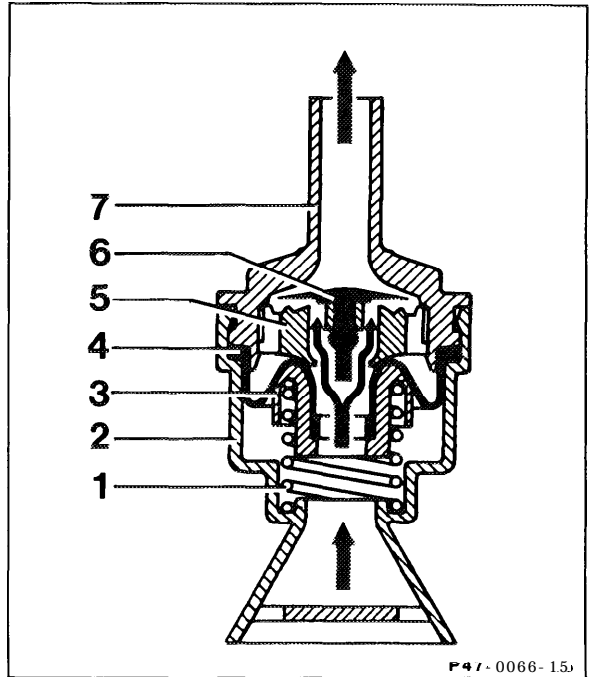

Vent system modified

The vent system has been modified by the addition of lines and siphon breakers (arrows) so that no fuel can escape through the vent system even under extreme conditions (rollover).

Standard implementation: phased-in (approx. 1 0/88)

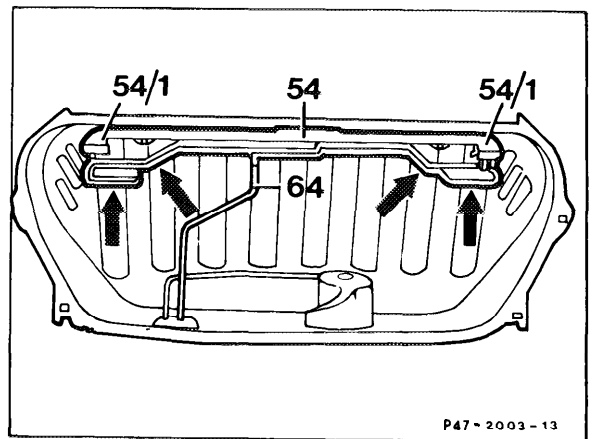

47-030 Function of fuel tank ventilation - Turbodiesel

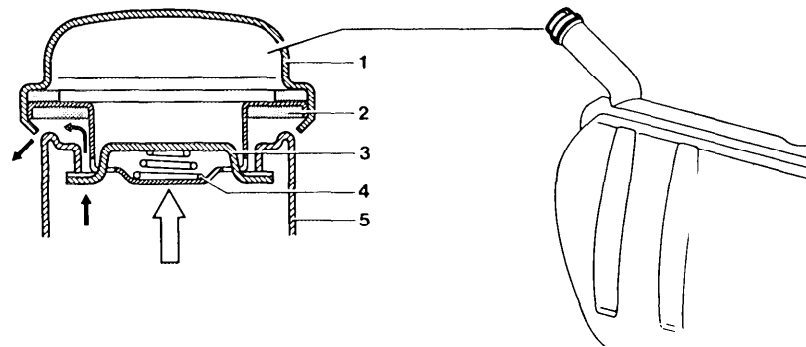

P47-0041-53

All Turbodiesel models

- 1 Cap
- 2 Sealing ring
- 3 Closing bar

Compression spring
Filler neck

At a gauge pressure of 100-300 mbar, vaporized fuel can escape through the fuel cap. This is only the case if the vent line from the fuel tank is not clear. If the system is operating properly, a gauge pressure of up to 50 mbar may be present in the fuel tank.

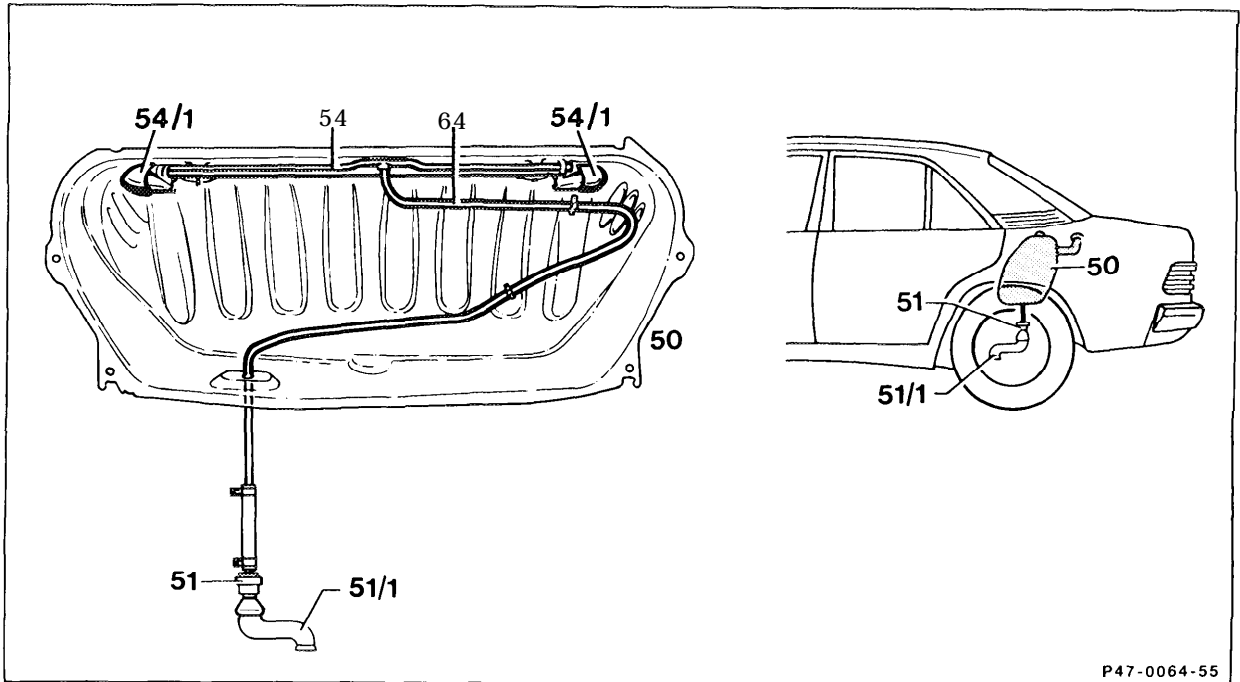

P47-0064-55

The vent system in the fuel tank (50) consists of a central pipe (54) each with a siphon breaker (54/1) at the ends. The siphon breakers prevent fuel escaping through the vent line.

The vent line (64) runs from the central pipe to the vent valve (51). The protective seal (51/1) at the end of the vent valve prevents dirt and splash water from getting into the vent valve.

If a gauge pressure of 30-50 mbar is present in the fuel tank, the vent valve (4) opens and allows the fuel vapors to escape.

- 1 Compression ring
- 2 Valve housing
- 3 Spring plate
- 4 Vent valve
- 5 Valve plate
- 6 Air admission valve
- 7 Connection fitting

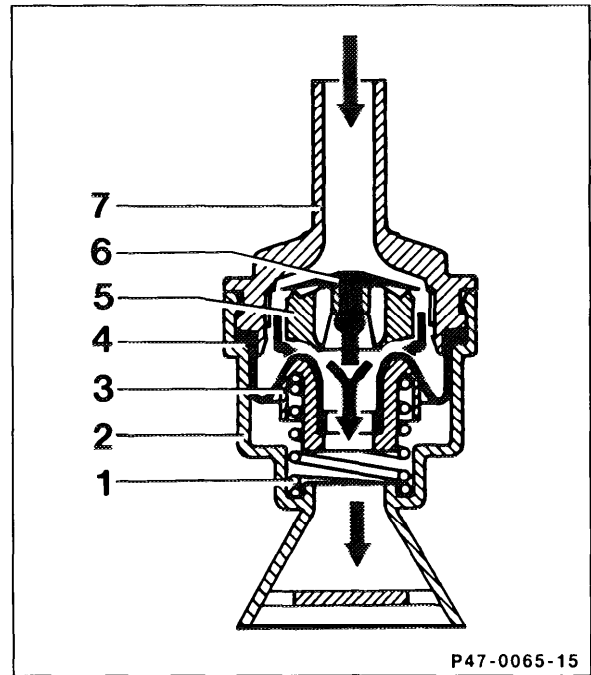

If a vacuum of 1-16 mbar is produced in the fuel tank, the air admission valve (6) opens.

Station wagons

These models are fitted with a modified vent valve with a bright base section. The performance is the same as for other vent valves.

- 1 Compression spring
- 2 Valve housing
- 3 Spring plate
- 4 Vent valve
- 5 Valve plate
- 6 Air admission valve
- 7 Connection fitting

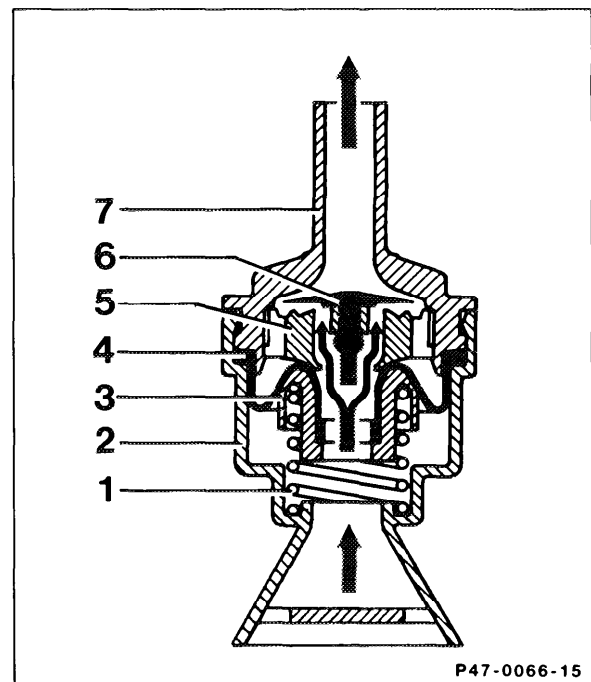

The dirt seal at the end of the vent valve prevents dirt and splash water from getting into the vent valve.

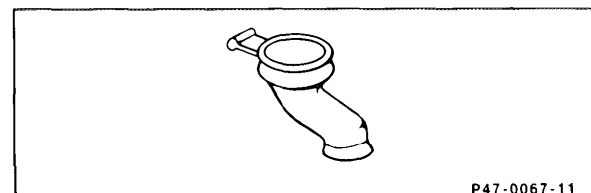

Modified vent system

The vent system has been modified by additional lines and siphon breakers (arrows) with the result that no fuel can escape through the vent system, even under extreme conditions (rollover).

Production breakpoint: phased in (approx. 10/88).

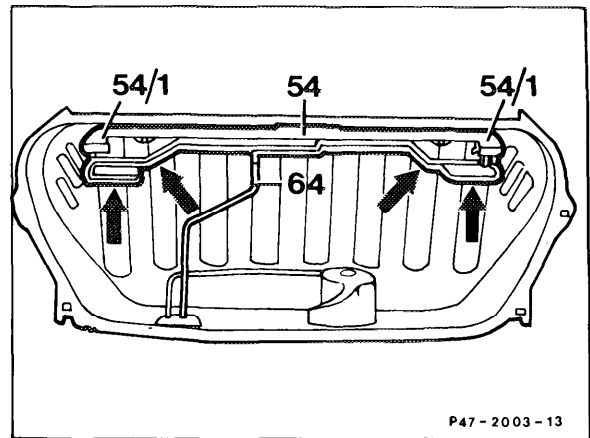

D. Model 201 naturally-aspirated versions

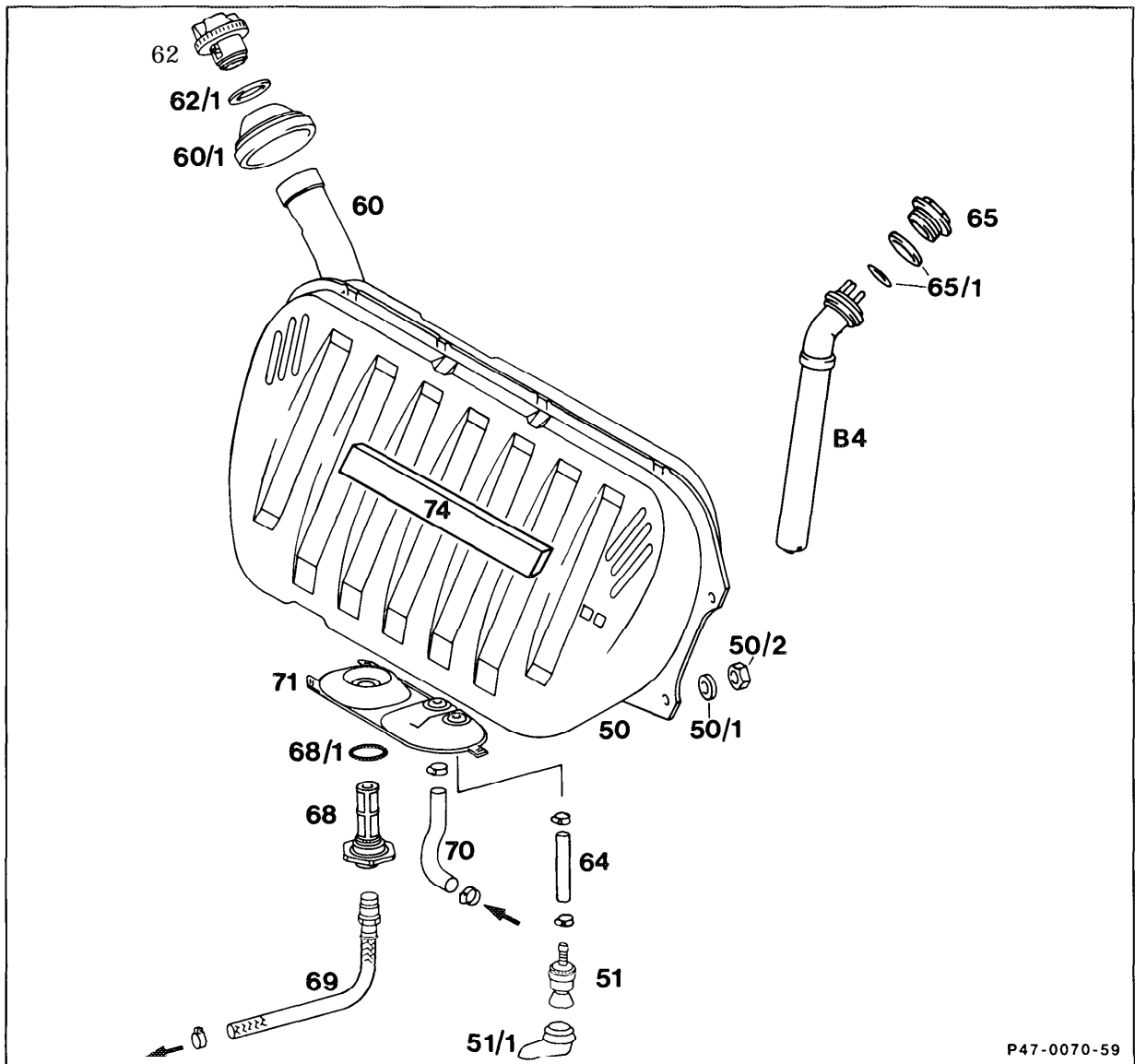

P47-0070-59

Safety regulations	Observe, risk of accident!
Battery ground cable	Disconnect, connect.
Filler cap (62)	Remove, fit. Check seal (62/1), replace if necessary.
Fuel tank (50)	Drain. Carefully pump out fuel to ensure no fuel remains in the tank. Capacity approx. 55 liters (14.5 US gal.) . Stick on 4 sound-absorbing strips (74), if necessary, with MB Universal Adhesive 000 989 92 71 (steel fuel tank only).
Cup seal (60/1)	Remove, Install.
Lining of fuel tank	Detach, attach.

Fuel gauge	Detach, fit on connector at sending unit (64). Check operation. Remove, install sending unit (B4), if necessary, 39 Nm (47-120). Replace seals.
Supply line (69), return line (70), vent valve (51)	Disconnect, connect, 28 Nm. Check for re-use. Collect remaining fuel. Seal connections. Ensure cup seal (71) is correctly seated.
Nut (50/2, 4 off)	21 Nm, use 4 washers (50/1).
Drain hose of tank recess	Before taking out the fuel tank, pull drain hose slightly up the way and lay to behind edge of fuel tank. Refit correctly after installation.
Fuel filter (68)	Remove, install if necessary, 39 Nm, clean. Check for reuse. Replace seal (6811).
Run engine briefly	Check connections and joints for leaks.

Repair instruction

Fuel tanks effective from 09/88 cannot be installed in cars manufactured prior to this date.

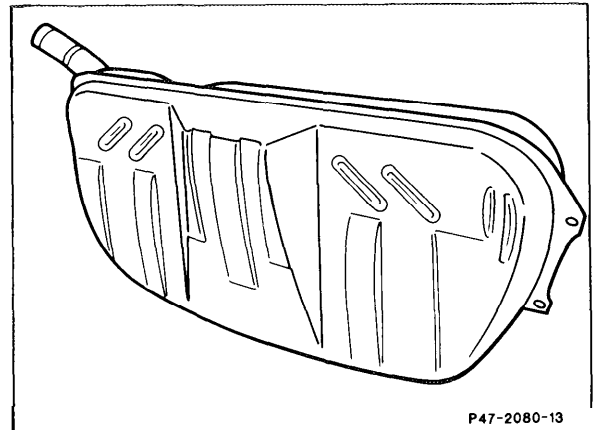

effective 09/88

P47-2080-13

E. Model 201 Turbodiesel versions

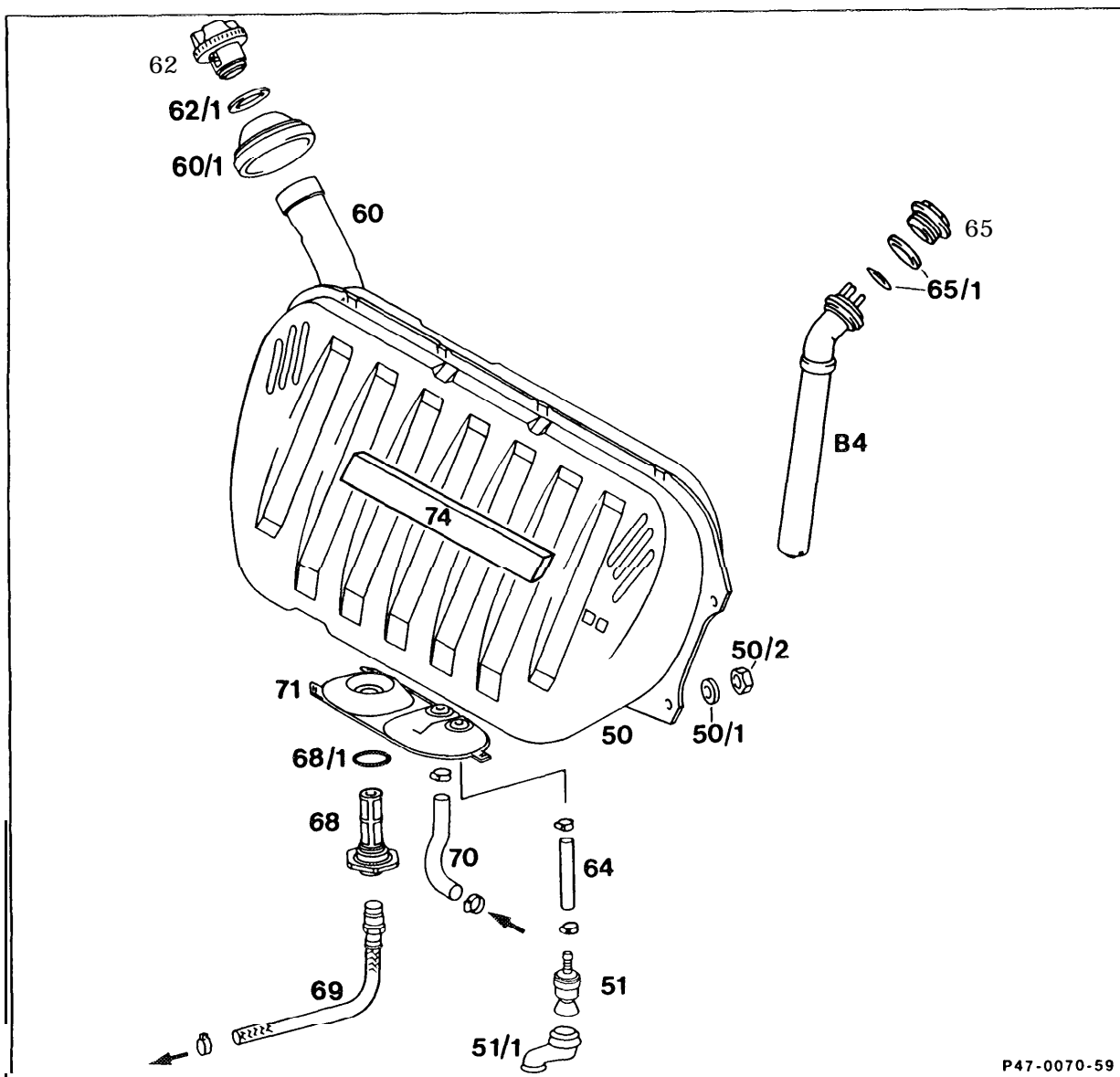

P47-0070-59

Safety regulations	observe, risk of accident!
Battery ground cable	disconnect, connect.
Cap(62)	remove, install. Check seal (62/1), renew if necessary.
Fuel tank (50)	drain. Carefully pump out fuel to ensure that there is no fuel remaining in the tank. Capacity approx. 55 litres. Stick 4 sound-deadening strips (74) with MB universal adhesive 000 989 92 71, if necessary.

Cup seal (60/1)	remove, install.
Panelling of fuel tank	detach, attach.
Fuel gauge	detach connector on sending unit (B4), fit on, check operation. Remove, install sending unit (B4) 39 Nm, if necessary (47-120). Renew seal rings.
Supply hose (69), return hose (70), vent valve (51) * *	disconnect, connect, 28 Nm. Check for re-use. Collect remaining fuel, seal connections. Ensure cup seal (71) is correctly fitted.
Nut (50/2, 4 off)	21 Nm. Use 4 shims (50/1).
Drain hose from tank recess	before removing the fuel tank, pull drain hose slightly upwards and lay over edge of fuel tank. Position correctly following installation.
Fuel filter (68)	if necessary, remove, install, clean, 39 Nm. Check for re-use. Replace seal (68/1).
Run engine briefly	Check joints for leaks.

47-120 Removal and installation of fuel gauge sending unit

A. Model 201

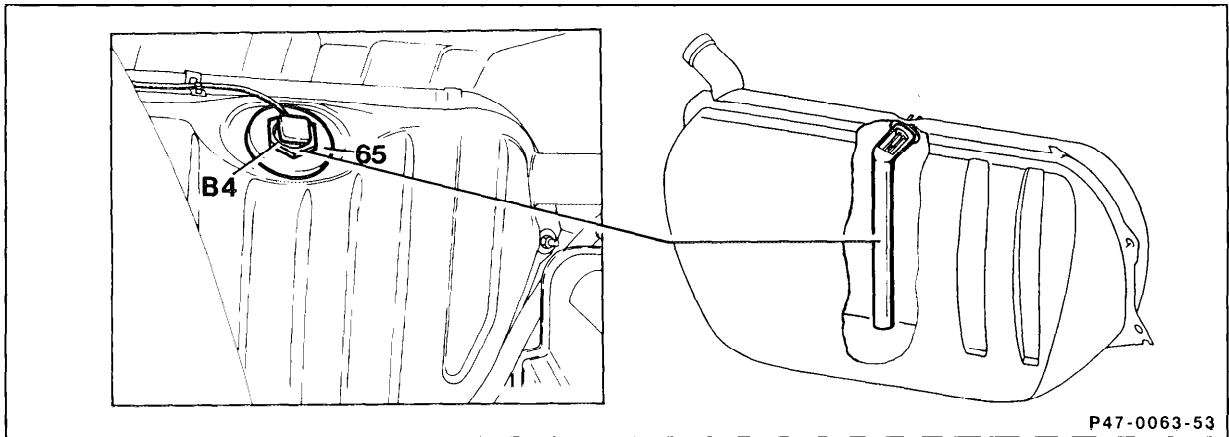

Battery ground cable	Disconnect, connect.
Fuel tank lining	Remove, install, Model 201 only partially.
Connector at sending unit (B4)	Remove, fit.
Sealing flange (65)	Unbolt, bolt on, 39 Nm. If fuel tank full, pump out approx. 8 litres (2 U.S. gal.) beforehand. Replace sealing rings.
Sending unit (B4)	Remove, install, run to drain, if necessary. Remove locking pin below adhesive strip (new part only).

Note

Refer to "Function of fuel gauge sending unit" (47-020) for fuel gauge sending unit Model 201.

B. Models 124, 201 Turbodiesel

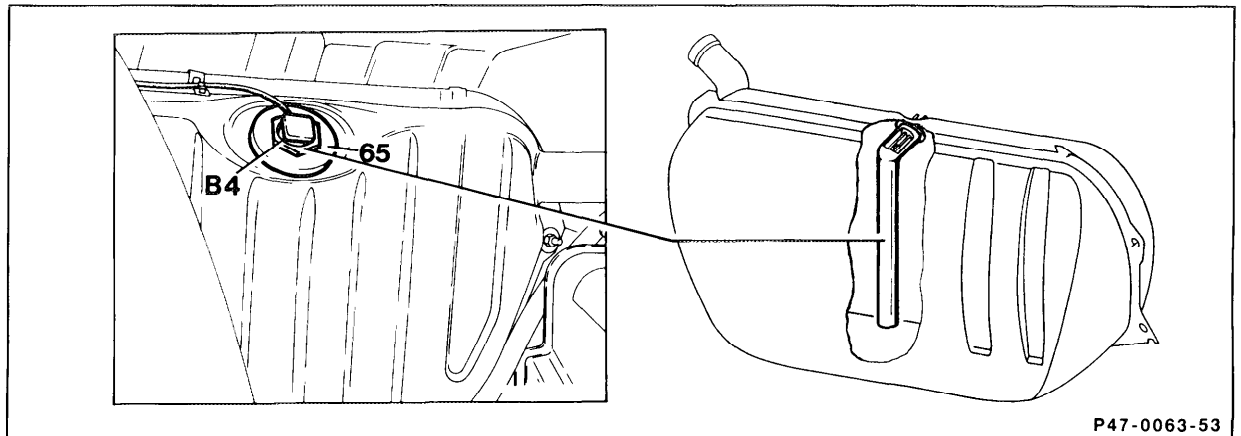

Battery ground cable	disconnect, connect.
Panelling of fuel tank	remove, install. Model 201 only partially.
Connector on sending unit (B4)	detach, fit on.
Sealing flange (65)	unbolt, bolt on, 39 Nm. Initially pump out approx. 8 litres (2 U.S. gal.) if fuel tank full. Replace seals.
Sending unit (B4)	remove, install. Empty by running if necessary. Remove locking pin below adhesive strip (new part only).