

- ENGINE 270 in MODEL 242
with CODE 924 (Bivalent natural gas drive)
- ENGINE 270, 607, 651 in MODEL 156
- ENGINE 270, 607, 651 in MODEL 176
- ENGINE 270, 651 in MODEL 117
- ENGINE 270, 651 in MODEL 246.2

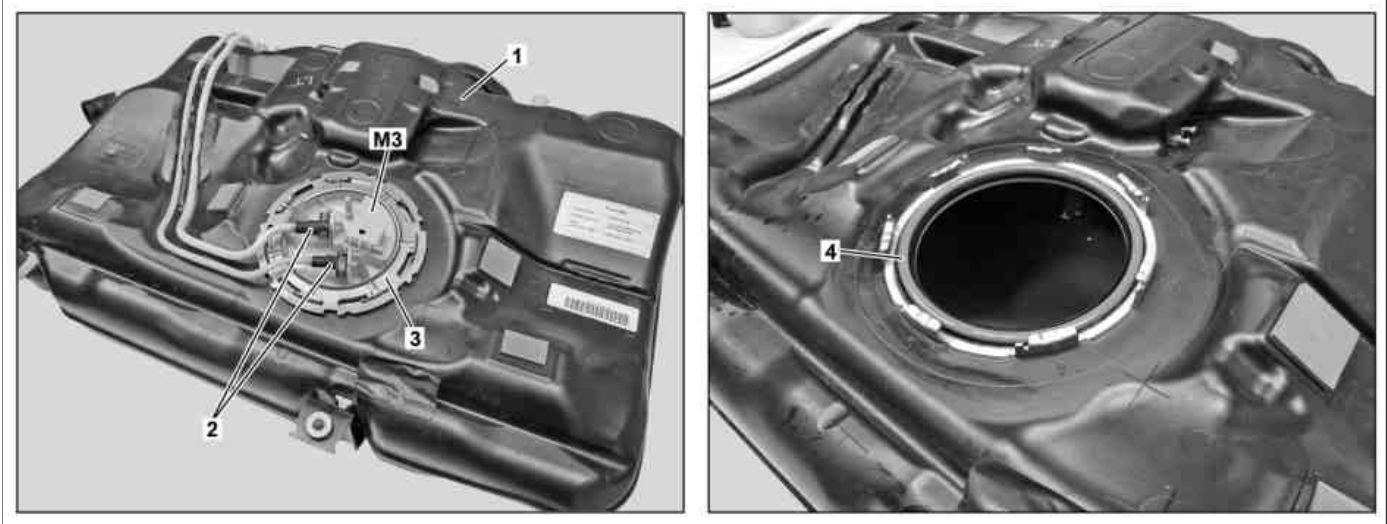

P47.20-2497-08

Shown on fuel tank for engine 651

- 1 Fuel tank
- 3 Locking ring
- M3 Fuel pump (FP)
- 2 Fuel lines
- 4 Sealing ring

Shown on fuel pump for engine 651

- B4/2 Fuel tank fuel level indicator fill level sensor, right
- M3 Fuel pump (FP)

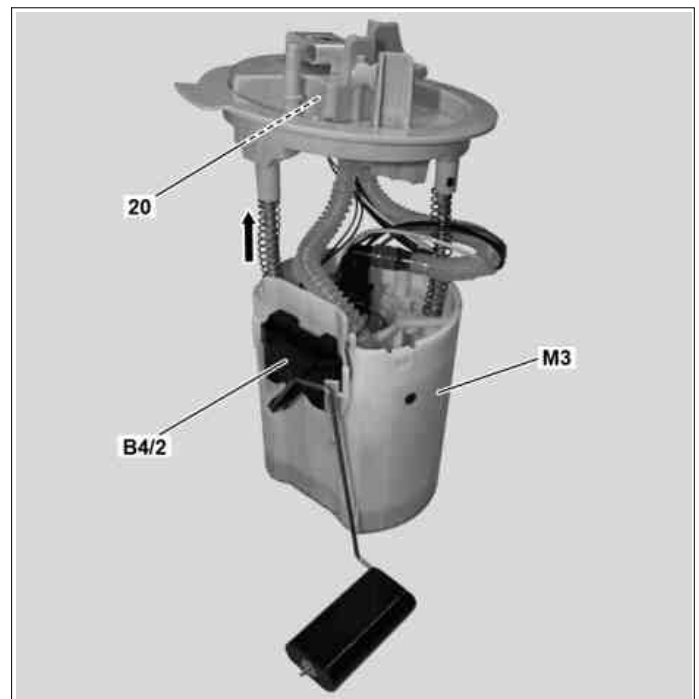

P47.10-2626-12

Danger!	Risk of explosion caused by fuel igniting, risk of poisoning caused by inhaling and swallowing fuel as well as risk of injury to eyes and skin caused by contact with fuel.	No fires, sparks, open flames or smoking. Pour fuels into suitable and appropriately marked containers only. Wear protective clothing when handling fuel.	AS47.00-Z-0001-01A
	Remove/install		